



LS values every single customer.
Quality and service come first at LSIS.
Always at your service, standing for our customers.

www.lsis.biz

LS Industrial Systems

10310000873

■ HEAD OFFICE

LS tower, Hogye-dong, Dongan-gu, Anyang-si, Gyeonggi-do
1026-6, Korea <http://eng.lsis.biz>
Tel. (82-2)2034-4689, 4888 Fax.(82-2)2034-4648

■ LS Industrial Systems Tokyo Office >> Japan

Address: 16F, Higashi-Kan, Akasaka Twin Towers 17- 22,
2-chome, Akasaka, Minato-ku, Tokyo 107-8470, Japan
Tel: 81-3-3582-9128 Fax: 81-3-3582-2667

e-mail: jschuna@lsis.biz

■ LS Industrial Systems Dubai Rep. Office >> UAE

Address: P.O.BOX-114216, API World Tower, 303B, Sheikh
Zayed road, Dubai, UAE. e-mail: hwvim@lsis.biz
Tel: 971-4-3328289 Fax: 971-4-3329444

■ LS-VINA Industrial Systems Co., Ltd. >> Vietnam

Address: LSIS VINA Congty che tao may dien Viet-Hung
Dong Anh Hanoi, Vietnam e-mail: sjio@hn.vnn.vn
Tel: 84-4-882-0222 Fax: 84-4-882-0220

■ LS Industrial Systems Hanoi Office >> Vietnam

Address: Room C21, 5th Floor, Horison Hotel, 40 Cat Linh,
Hanoi, Vietnam
Tel: 84-4-736-6270/1 Fax: 84-4-736-6269

■ Dalian LS Industrial Systems co., Ltd, >> China

Address: No. 15 Liaohexi 3 Road, economic and technical
development zone, Dalian, China e-mail: lxk@lqis.com.cn
Tel: 86-411-8273-7777 Fax: 86-411-8730-7560

■ LS Industrial Systems (Shanghai) Co., Ltd. >> China

Address: Room E-G, 12th Floor Huamin Empire Plaza,
No. 726, West Yan'an Road, Shanghai, China
Tel: 86-21-5237-9977

■ LS Industrial Systems(Wuxi) Co., Ltd. >> China

Address: 102-A National High & New Tech Industrial
Development Area, Wuxi, Jiangsu, China e-mail: Xugh@lqis.com.cn
Tel: 86-510-534-6666 Fax: 86-510-522-4078

■ LS Industrial Systems Beijing Office >> China

Address: B-tower 17th Floor, Beijing Global Trade Center building,
No. 36, BeiSanHuanDong-Lu, DongCheng-District, Beijing, China
Tel: 86-10-5825-6025

■ LS Industrial Systems Guangzhou Office >> China

Address: Room 1403, 14F, New Poly Tower, 2 Zhongshan Liu
Rad, Guangzhou, China e-mail: zhangch@lqis.com.cn
Tel: 86-20-8326-6754 Fax: 86-20-8326-6287

■ LS Industrial Systems Chengdu Office >> China

Address: Room 2907, Zhong Yin B/D, No. 35, Renminzhong(2)-
Road, Chengdu, China e-mail: hongkonk@vip.163.com
Tel: 86-28-8612-9151 Fax: 86-28-8612-9236

■ LS Industrial Systems Qingdao Office >> China

Address: 12th Floor, Guodong building, No52 Jindun Road,
Chengdu, China e-mail: bellkuk@hanmail.net
Tel: 86-532-580-2539 Fax: 86-532-583-3793

※ LS Industrial Systems constantly endeavors to improve its product so that
Information in this manual is subject to change without notice.

© LS Industrial systems Co., Ltd 2006 All Rights Reserved.

XGB FEnet/2008. 1

XGT Series

XGB Fast Ethernet I/F Module

Right choice for ultimate yield

LSIS strives to maximize customers' profit in gratitude of choosing us for your partner.

Programmable Logic Controller

XGB Fast Ethernet I/F Module

XGT Series

User's Manual

XBL-EMTA

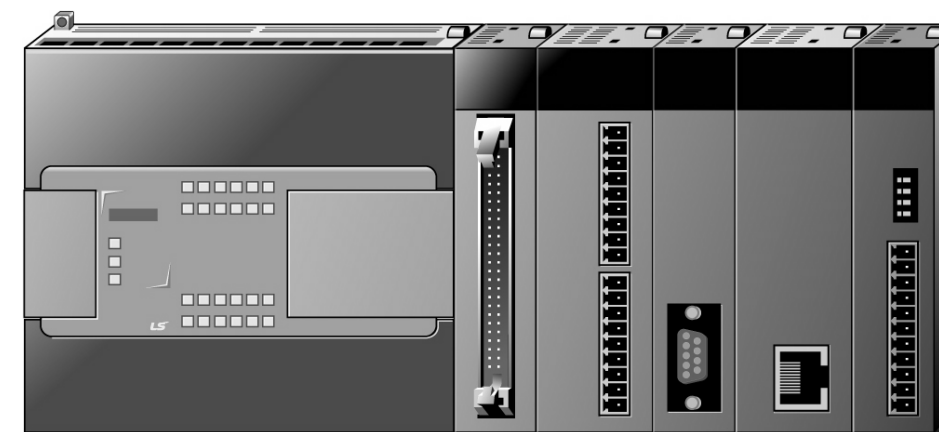
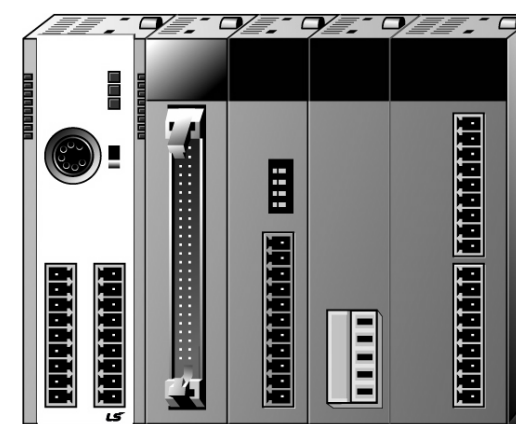

! Safety Instructions

• Read this manual carefully before installing, wiring, operating, servicing or inspecting this equipment.

• Keep this manual within easy reach for quick reference.

LS Industrial Systems

Revision History

Version	Date	History	Remark
V 1.0	July.2007	First edition	

※ The number of user manual is indicated right part of the back cover.
© LS Industrial Systems Co., Ltd 2007 All Rights Reserved.

[Contents]

- Chapter 1 General 5
 - 1.1 Before Reading This Manual 5
 - 1.2 Before Using This Device 5
 - 1.2.1 Relevant user manuals 5
 - 1.2.2 Version Information 5
 - 1.3 Characteristics 5
 - 1.3.1 XGB Fast Ethernet I/F module characteristics 5
 - 1.3.2 Designation 6
 - 1.3.3 Max. modules can be installed 6
 - 1.3.4 Relevant software 6
- Chapter 2 Specifications 7
 - 2.1 General Specifications 7
 - 2.2 Transmission Specifications 8
 - 2.3 Cable Specifications 8
 - 2.3.1 Cable classification 8
 - 2.3.2 Frequency classification 9
 - 2.3.3 Category 5 twisted paired cable (UTP) examples (CTP-LAN5) 10
 - 2.4 Performance Specifications 11
 - 2.4.1 General performance specifications 11
 - 2.4.2 Performance Specifications by Communication Service 11
 - 2.4.3 Diagnosis function specifications 12
 - 2.5 Dimensions and Names of Parts 13
 - 2.5.1 Dimensions and names of parts 13
 - 2.5.2 Designation of Parts 13
- Chapter 3 Installation 14
 - 3.1 Cautions for Installation 14
 - 3.1.1 Environmental conditions 14
 - 3.1.2 Installation cautions 14
 - 3.1.3 Handling cautions 14
 - 3.2 Installation and wiring 15
 - 3.2.1 Network connection 15
 - 3.2.2 UTP cable wiring 15
 - 3.2.3 Cautions for system and network connection 16
 - 3.2.4 Check points before start-up 17
- Chapter 4 System configuration 18
 - 4.1 General 18
 - 4.1.1 General 18
 - 4.2 Examples of system configuration 18
 - 4.2.1 Combination network configuration 18
 - 4.2.2 Network configuration using XGB 18
 - 4.2.3 Network configuration using XGB and MMI 19
 - 4.2.4 Network configuration between LSIS modules 19

4.2.5 Network configuration using XGB and other LSIS PLC	19
Chapter 5 Protocols of various services	20
5.1 General	20
5.1.1 XGB Fast Enet I/F module protocol introduction	20
5.1.2 Protocol by service	20
5.2 XGT dedicated protocol	21
5.2.1 General	21
5.2.2 Frame structure	21
5.2.3 XGT dedicated protocol data type	22
5.2.4 Instruction of XGT dedicated protocol	22
5.2.5 Header and data structure of XGT dedicated protocol	23
5.2.6 Frame examples	24
5.3 Modbus TCP/IP protocol	26
5.3.1 General	26
5.3.2 Structure of Modbus TCP/IP frame	26
5.3.3 MBAP Header structure	27
5.3.4 Available function code	27
5.3.5 Frame structure by function code	27
Chapter 6 Dedicated Service	34
6.1 Dedicated Service Function Introduction	34
6.1.1 Server model	34
6.1.2 System configuration	34
6.1.3 Dedicated service classification	34
6.2 Setting Dedicated Service	35
6.2.1 Basic parameter	35
6.3 XGT Server	37
6.3.1 TCP XGT server	37
6.4 Modbus TCP/IP Server	38
Chapter 7 P2P Service	39
7.1 P2P Service Function Introduction	39
7.1.1 Client model	39
7.2 Setting P2P Service	40
7.2.1 Setting P2P parameter	40
7.2.2 Enable link	45
7.3 XGT Client	47
7.3.1 XGT client introduction	47
7.4 Modbus TCP Client	48
7.4.1 Modbus TCP Client	48
7.5 User define frame	49
7.5.1 TCP user define frame client	49
7.5.2 TCP/UDP user define frame server	57
7.5.3 TCP user define frame client	58
7.6 P2P Diagnosis Function	59
7.6.1 Service condition diagnosis using XG-PD	59
Chapter 8 High Speed Link Service	61
8.1 General	61

Contents

8.1.1 General.....	61
8.2 Setting HS link service.....	61
8.2.1 Basic parameter.....	61
8.2.2 HS link parameter.....	62
8.3 HS Link Flag.....	67
8.3.1 HS link flag classification.....	67
8.3.2 HS link flag introduction.....	67
8.3.3 HS link flag memory address.....	68
Chapter 9 Remote Communication Control.....	70
9.1 General.....	70
9.2.1 Remote 1 (RS-232C Cable).....	72
9.2.2 Remote 2 (RS-232C Cable).....	74
9.2.3 Direct remote 1 on Enet connecting PC.....	76
9.2.4 Direct remote 2 on Enet connecting PC.....	78
Chapter 10 Troubleshooting.....	80
Warranty.....	82

Chapter 1 General

1.1 Before Reading This Manual

This manual includes specifications, installations and various services for Fast Ethernet Interface Module of XGB Ethernet PLC (Hereafter, referred to as **XGB Fast Enet I/F module**, 100Mbps). Ethernet is one of technical standards of IEEE. It provides HS data communication on the base of CSMA/CD network.

XGB Fast Enet I/F module is an interface module for data communication between PC devices by using the electrical media (10/100BASE-TX, 100BASE-FX).

1.2 Before Using This Device

1.2.1 Relevant user manuals

Refer to below user manuals for achieving program.

- (1) XGT PLC Instruction and Programming manual
- (2) XG5000 manual
- (3) XGB series manual

1.2.2 Version Information

XGB series Fast Enet I/F module (XBL-EMTA) is suitable to following versions.

- (1) XG5000 programming tool: above Ver 2.0
- (2) XG-PD: above Ver 2.0
- (3) XGB CPU: above Ver 1.4

1.3 Characteristics

XGB Fast Enet I/F module provides its services for ARP, ICMP, TCP/IP and UDP/IP protocol and includes following characteristics.

1.3.1 XGB Fast Ethernet I/F module characteristics

- (1) Ethernet II, IEEE 802.3 standard functions
- (2) HS link function for HS data communication between LSIS modules
 - (a) Communication dedicated parameter setting program (XG-PD)
 - (b) Transmission Max. 32 blocks x 200 words, Reception, Max. 64 block x 200 words, Transmission-Reception Max. 64 blocks x 200 words)
- (3) HS link and communication is available with Max. 4 modules (Dedicated communication + P2P communication)
- (4) **Loader service** by Enet (XG5000): (Dedicated TCP/IP PORT: 2002 assignment)
- (5) Connection to other system is available by using P2P communication and XG-PD (Variable READ/WRITE services (Dynamic Connection function))

Chapter 1 General

- (6) Auto/10/100BASE-TX media service
- (7) Various communication functions
 - (a) System connection by using public network
 - (b) LSIS protocol (XGT) and other company protocol (Modbus TCP/IP) (dedicated service)
 - (c) Simple client function for the communication between LSIS communication module and other company communication module (XGT, Modbus TCP, user define P2P client function)
 - (d) Host enable table for Upper PC (MMI) and communication protection
 - (e) Dynamic Connection/Disconnection function by using P2P service
- (8) Various diagnosis functions, module and network condition information
 - (a) CPU module condition
 - (b) Communication module condition
 - (c) Communication service (HS link, main service, P2P) condition
 - (d) PING function to check the existence of other module
 - (e) Packet types and minute packet reception rate to LSIS communication module (it predicts network load)
 - (f) Diagnosis function for communication module by network

1.3.2 Designation

XGB Fast Enet I/F module designates as bellows.

Designation	Description	Remark
XBL-EMTA	10/100BASE-TX	Over category 5, UTP cable

[Table 1-1] XBL-EMTA Designation

1.3.3 Max. modules can be installed

XGB series can be installed max. 2 communication modules.

Series	Max. modules can be installed
XGB	2

[Table 1-2] Max. modules can be installed

1.3.4 Relevant software

Essential programming tools and other configuration software for using XGB Fast Enet I/F module is as followings.

Refer to followings and apply this suggestion for the right program and communication.

Designation	Programming Tool	Communication Setting Tool
XBL-EMTA	XG5000 (more than Ver. 2.0)	XG-PD (more than Ver. 2.0)

[Table 1-3] Relevant software

Remark

- 1) Download and usage of upper program is available at <http://www.lsis.biz> or this program installation CD's can be provided at the nearest shop.
- 2) Programming for XG5000 and XG-PD is available by using CPU module **loader port** and refer to cables from the wiring diagram of relevant CPU modules.

Chapter 2 Specifications

2.1 General Specifications

[Table 2-1] shows general specification of XGB series.

No.	Item	Specifications	References		
1	Operating Temp.	0°C ~ +55°C			
2	Storage Temp.	-25°C ~ +70°C			
3	Operating Humidity	5~95%RH, non-condensing.			
4	Storage Humidity	5~95%RH, non-condensing.			
5	Vibrations	Occasional vibration		-	
		Frequency	Acceleration	Amplitude	Sweep count
		10 ≤ f < 57Hz	-	0.075mm	10 times for each X, Y, Z axis
		57 ≤ f ≤ 150Hz	9.8m/s ² {1G}	-	
		Continuous vibration			
		Frequency	Acceleration	Amplitude	
		10 ≤ f < 57Hz	-	0.035mm	
57 ≤ f ≤ 150Hz	4.9m/s ² {0.5G}	-			
6	Shocks	<ul style="list-style-type: none"> • Maximum shock acceleration : 147 m/s² (15g) • Duration time: 11 ms • Pulse wave : half sine pulse(3 shocks per axis, on X,Y,Z axis) 	IEC61131-2		
7	Noise Immunity	Square wave Impulse noise	±900V	LSIS internal standard	
		Electronic discharge	Voltage: ±4 kV(Discharge by contact)	IEC61131-2 IEC61000-2	
		Radiated electromagnetic field noise	27~500MHz, 10V/m	IEC61131-2 IEC61000-4-3	
		Fast transient & Burst noise	Item	Power supply	Digital I/O Analog I/O Communication Interface
Voltage	2kV		1kV		
8	Atmosphere	Free of corrosive gases and excessive dust			
9	Cooling method	Natural air-cooling			
10	Altitude	Up to 2,000m			
11	Pollution degree	Less than 2			

[Table 2-1] General specification

Remark

- 1) IEC (International Electro-technical Commission): An international civilian institute who establishes international standards in the area of electric and electronics.
 - 2) Pollution degree: An indicator, which indicates pollution degree, which determine insulation performance of equipment.
- * Pollution degree 2: Normally, only non-conductive pollution occurs. Occasionally, however, a temporary conductivity caused by condensation shall be expected.

2.2 Transmission Specifications

[Table 2-2] shows transmission specifications of XGB Fast Enet I/F module media.

	Item	Specifications	Remark
Transmission specifications	Transmission speed	Auto/10M/100Mbps	-
	Transmission type	Base band	-
	Flow control	HALF/FULL	-
	Modulation Type	NRZI	•4B/5B coding
	Transformer CT	1:1	•Node-Hub
	Max. distance between nodes	100m	-
	Max. segment length	-	-
	Max. number of nodes	Hub connection	-
	Node interval	-	-
	Max. protocol size	Data 512byte	-
	Communication zone access method	CSMA/CD	-
	Check method of frame error	CRC32	-

[Table 2-2] Transmission specifications

2.3 Cable Specifications

2.3.1 Cable classification

XGB Fast Enet I/F module takes UTP cable which is over Cat 5. [Table 2-3] shows cable specifications.

Classification	Details	Purpose
UTP(or U.UTP)	So called unshielded cable used for HS signal	<ul style="list-style-type: none"> • Max. 200MHz • Phonetic + Data + low grade of video signal
FTP(or S.UTP)	Cable with cable core only shielded solely	<ul style="list-style-type: none"> • Max.100MHz • Electronic impediment (EMI) and electric stability considered • Phonetic + Data + low grade of video signal(
STP(or S.STP)	Double-shielded structure, pair shielded and core shielded cable	<ul style="list-style-type: none"> • Max. 500MHz • Phonetic + Data + Video signal • Substitute for 75Ω coaxial cable

[Table 2-3] Cable class

Remark

- 1) XGB Fast Enet I/F module does not support AUI (10BASE-5).
- 2) Twisted paired cable unit (above category 5) takes 100Mbps class hub and if network speed is 10 Mbps, it can be used with 10Mbps class hub (below category 3). Make sure this to install system.

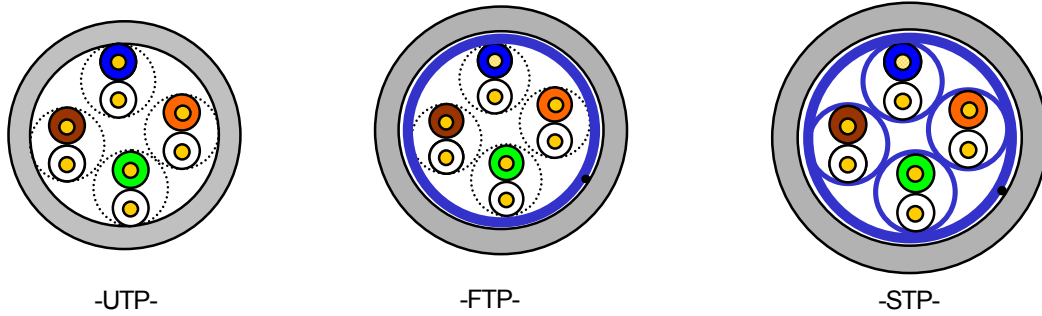

Remark

1) UTP : Unshielded Twisted Paired Copper Cable
 FTP : (Overall) Foiled Twisted Paired Copper Cable
 STP : (Overall) Shielded (and Shielded Individually Pair) Twisted Paired Copper Cable

2) Patch Cable (or Patch Cord)
 Stranded conductor composed of stranded cable instead of solid conductor may be used to increase the flexibility of UTP 4-paired cable. Representative specification and material are un-coated AWG 24 (7/0203A).
 In other words, the diameter of a single cable is 0.203mm, and this cable is of 1+6 structure as standardized with annealed copper cable.

2.3.2 Frequency classification

Classification	Frequency (MHz)	Transmission speed (Mbps)	Purpose
Category 1	Phonetic frequency	1	• Phone network (2-Pair)
Category 2	4	4	• Multi-Pair communication cable
Category 3	16	16	• Phone network + computer network
Category 4	20	20	• Computer network transmission speed up • Low- loss communication cable
Category 5 & Enhanced Category5	100	100	• Digital phone network + computer network • Low -loss, broadband cable

[Table 2-4] Frequency classification

Remark

1) Presently classified items are Category 3, 5, Enhanced Category 5 and Category 6 inside and outside of the country, where Category 4 has been replaced by Category 5 and Category 7 is being under development all over the world as STP structure.

2.3.3 Category 5 twisted paired cable (UTP) examples (CTP-LAN5)

Item	Unit	Value	
Conductor resistance (Max.)	Ω/km	93.5	
Insulation resistance (Min.)	$\text{M}\Omega\cdot\text{km}$	2,500	
Withstand voltage	V/min	AC 500	
Characteristic impedance	$\Omega(1\sim 100\text{MHz})$	100 ± 15	
Decrement	Below dB/100m	10MHz	6.5
		16MHz	8.2
		20MHz	9.3
Near-end crosstalk decrement	Below dB/100m	10MHz	47
		16MHz	44
		20MHz	42

[Table 2-5] UTP cable specification

2.4 Performance Specifications

2.4.1 General performance specifications

[Table 2-6] shows general performance specifications of XGB Fast Enet I/F module.

Item		Specifications	Remark
Max. modules can be installed		2	▪ Per 1 CPU unit
Max. numbers of connection channels		6 channels	▪ TCP/IP : 4 channels ▪ Remote 1: 1 channel ▪ Remote 2: 1 channel
Consumption	DC 5V	300mA	-
Weight		71g	-

[Table 2-6] General performance specifications

2.4.2 Performance Specifications by Communication Service

[Table 2-7] shows performance specifications by communication service of XGB Fast Enet I/F module.

Item		Specifications			Remark
		Driver	Communication method	Port Number	
Function classification	Dedicated	XGT server	TCP/IP	2004	▪ Max. 4 channels ▪ Max. 512 bytes
			UDP/IP	2005	
		Mod bus TCP server	TCP/IP	502	
	HS link	-	UDP/IP	2006	▪ Max. 64 blocks ▪ 200 words per block
	P2P	XGT client	TCP/IP	2006	▪ Max. 3 channels ▪ Max. 32 blocks ▪ Max. 512 bytes
			UDP/IP	2005	
		Mod bus TCP client	TCP/IP	502	
		User define frame	TCP/IP	User's assignment	
UDP/IP	User's assignment				

[Table 2-7] Performance specifications by communication service

Chapter 2 Specifications

2.4.3 Diagnosis function specifications

[Table 2-8] shows diagnosis function specifications of XGB Fast Enet I/F module.

Item		Specifications	
Diagnosis Function	Communication module information	<ul style="list-style-type: none"> ▪ HS link station no. ▪ IP/Subnet mask IP/Gateway IP/DNS Server IP ▪ Main service/HS link/P2P enable ▪ Setting media ▪ Hardware/ software version 	
	Service condition	Dedicated service	<ul style="list-style-type: none"> ▪ Transmission packet number / Reception packet number / Error packet number / State ▪ Setting drive
		HS link	<ul style="list-style-type: none"> ▪ Transmission/ Reception packet number ▪ HS link flag(Run, Link, Mode, State, TRX, Error)
		P2P service	<ul style="list-style-type: none"> ▪ Connection state / Service state ▪ Service count / Error count
	Media Information	Total transmission/Reception packet number	<ul style="list-style-type: none"> ▪ Broad, Multi, Uni, UDP, ARP, EARP, Throw-out
		Packet Rate per sec.	
	Ping test	<ul style="list-style-type: none"> ▪ IP Address / Setting times / Time out 	
	Auto scan	Non- service	

[Table 2-8] Diagnosis function specification

2.5 Dimensions and Names of Parts

2.5.1 Dimensions and names of parts

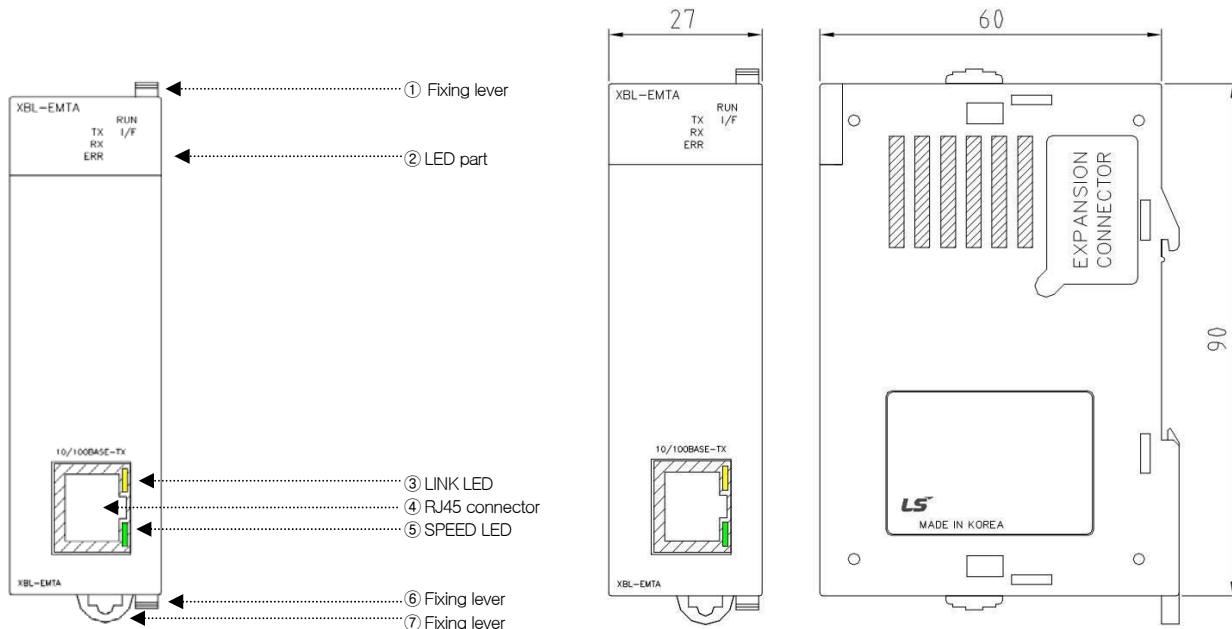

[Fig. 2-1] Dimensions and names of parts

2.5.2 Designation of Parts

Item		Description		
①	Fixing lever	Extension module fixing part (the upper)		
②	LED	RUN	On	Normal operating
			Off	Stop operating
		I/F	flicker	CPU and I/F
			Off	Stop CPU and I/F
		TX	flicker	Data transmission time
			Off	Stop data transmitting
		RX	flicker	Data receiving time
			Off	No data reception
ERR	On	H/W error		
	flicker	S/W error		
③	LINK LED (Yellow)	flicker	Packet reception time	
		Off	No packet reception	
④	RJ45 connector	RJ45 connector part		
⑤	SPEED LED (Green)	On	100Mbps operating time	
		Off	10Mbps operating time	
⑥	Fixing lever	Expansion module fixing part (the lower)		
⑦	Fixing lever	DIN rail fixing part		

[Table 2-9] Designation of Parts

Chapter 3 Installation

3.1 Cautions for Installation

This device has high reliability regardless of its installation environment. But the followings should be noted for securing reliability and stability.

3.1.1 Environmental conditions

- (1) Install on a water-proof and dust control panel
- (2) Place free of continuous impact or vibration
- (3) Place out of direct sunrays
- (4) Place without dewing by sudden temperature change
- (5) Place where ambient temperature is between 0-55℃.

3.1.2 Installation cautions

- (1) If producing screw holes or wiring, it should be noted that any impurities from wiring work are not to be inserted into PLC.
- (2) Install on an accessible place.
- (3) Do not install on high voltage device or same panel.
- (4) Continuous it 50mm and wider out of duct or surrounding modules.
- (5) Ground on a place where little noise is detected

3.1.3 Handling cautions

- (1) Do not drop or do not apply any excessive impact on it.
- (2) Do not separate PCB from case(shield), which may cause breakage.
- (3) Make sure that while wiring, any impurities should not be inserted into the upper part of this module.
- (4) Do not attach or detach the module once power is on.
- (5) Cable should be selected considering the approved specification, install this device within the permitted max. distance.
- (6) AC and external I/O signal of positioning module are not subject to any surge or induced noise generated from AC.
- (7) If wiring is too close to any hot devices or materials or contacts with oils for a long time, it may cause short circuit, malfunction or destruction.
- (8) If wiring by using pipes, it needs grounding pipes.

3.2 Installation and Wiring

3.2.1 Network connection

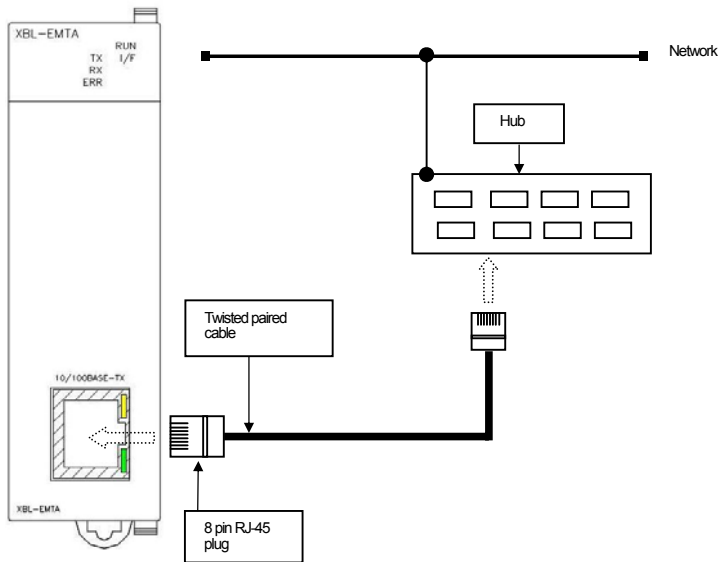

[Fig. 3-1] Network connection

3.2.2 UTP cable wiring

Max. distance between nodes of 10/100BASE-TX is 100m(module - Hub).

The hub is in general use straight cable with TD and RD stranded inside. If only 2 of these communication modules are connected 1 to 1, cross-cable form may be used.

Pin no.	Signal	Straight cable (module-Hub)	1 to 1 cross-cable
1	TD+	1—1	1—3
2	TD-	2—2	2—6
3	RD+	3—3	3—1
6	RD-	6—6	6—2
4, 5, 7, 8	N/A		

[Table 3-1] Cable wiring

Remark

- 1) Hub power should be separated from PLC power.
- 2) Contact professional manufacturers for processing cable terminal, manufacture and installation.

Chapter 3 Installation

(1) Cautions for UTP installation

- (a) UTP cable should be satisfied the characteristics of category 5.
- (b) Do not access Max. tension strength of the cable during a period of wiring processing.
- (c) Do remove only the length of wiring, do not damage the insulator for removing covering (Sheath).
- (d) Keep suitable distance between EMI source and UTP cable during the period of installing UTP cable.

Condition	Min. separation distance		
	2.0KVA or less	2.5 KVA	5.0KVA or more
Power line unshielded, or electric facility open or near to nonmetallic pipe	127mm	305mm	610mm
Power line unshielded, or electric facility near to metallic pipe buried	64mm	152mm	305mm
Power line inside metallic pipe buried (or equivalently shielded) near to metallic pipe buried	-	76mm	152mm
Transformer / Electric motor light	1,016mm /305mm		

[Table 3-2] Cautions for UTP installation

3.2.3 Cautions for system and network connection

- (1) IP address should be different including this module. If not, normal communication is not available.
- (2) Set each exchange number differently for using HS link service.
- (3) Use specified communication cable. Other cables may occur communication trouble.
- (4) Check disconnection or short circuit of communication cable before installation.
- (5) Do tighten communication cable connector.
- (6) If cable connection is not stable, it may occur some severe trouble of communication.
- (7) Do wiring processing of communication cable separately from power supply line or inductive noise.

3.2.4 Check points before start-up

The following describes check points before start-up communication module.

(1) Communication module

Check points
Installation and operation of XG5000, Performance and operation of XG-PD
Connection condition of communication cable (only the condition of connecting cable)
Module installation condition

[Table 3-3] Check points before start-up

(2) Start-up processing

It shows start-up from finishing installation of module on PLC.

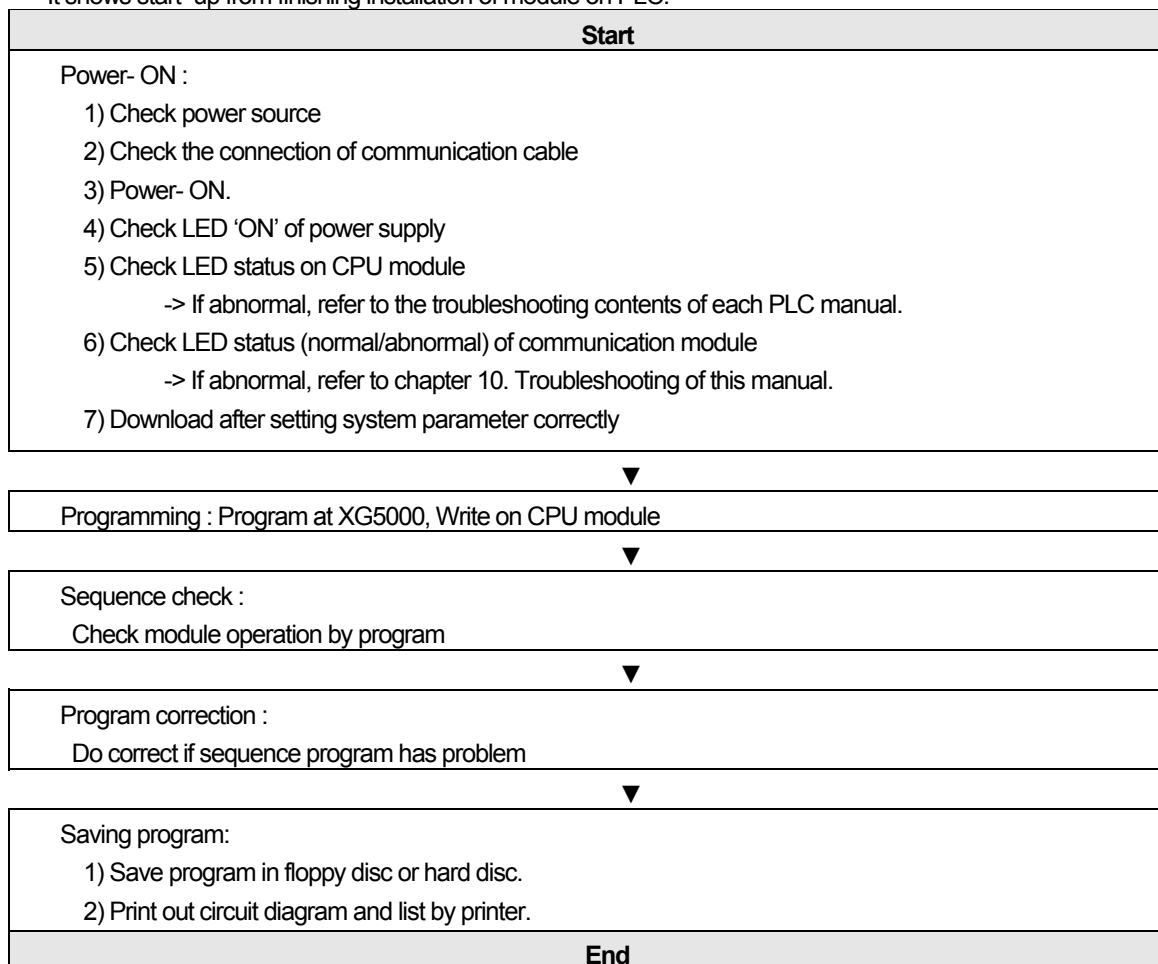

Chapter 4 System Configuration

4.1 General

4.1.1 General

XGB Fast Enet I/F module supports open Enet. It provides network configuration that is to connect LSIS and other company PLC, PC on network.

4.2 Examples of System Configuration

4.2.1 Combination network configuration

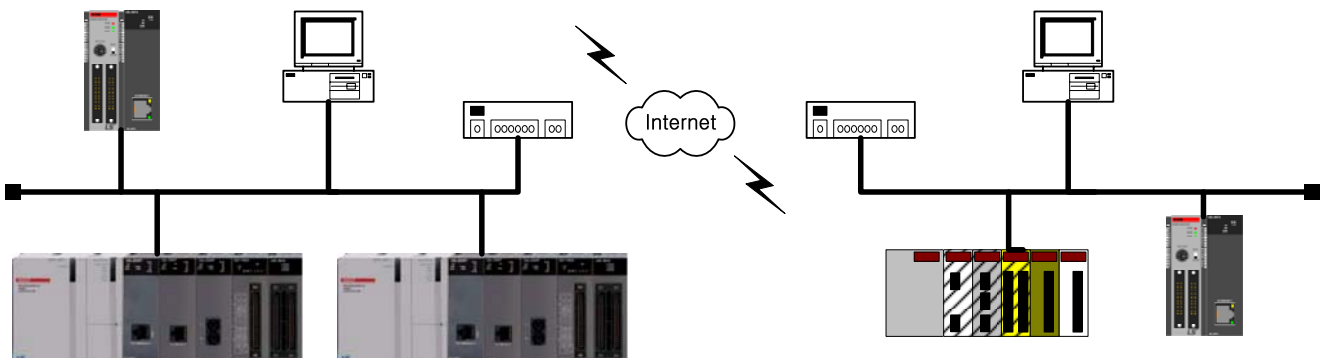

[Figure 4-1] Combination network configuration

XGB Fast Enet I/F module provides system configuration by using main communication, Modbus TCP/IP, user define frame, HS link communication connecting LSIS PLC with other LSIS PLC, PC on network.

4.2.2 Network configuration using XGB

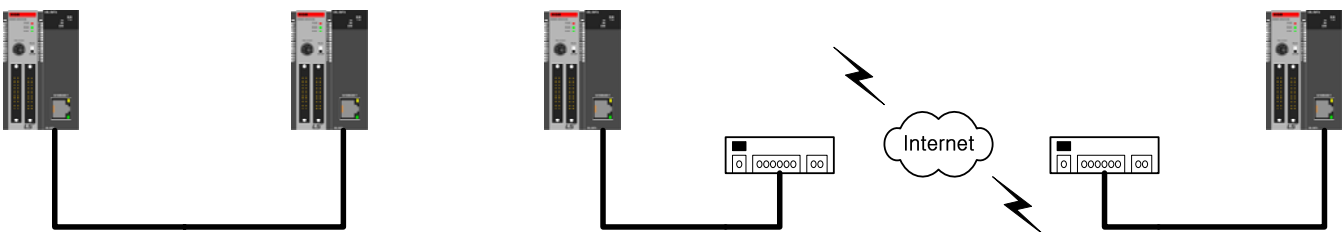

[Figure 4-2] Network configuration using XGB

Communication between XGB Fast Enet I/F modules is available to perform 1:1 communication by using cross cable or 1:N communication by connecting network. It provides data sending/receiving by using the dedicated service, Modbus TCP/IP, user define frame and HS link communication.

4.2.3 Network configuration using XGB and MMI

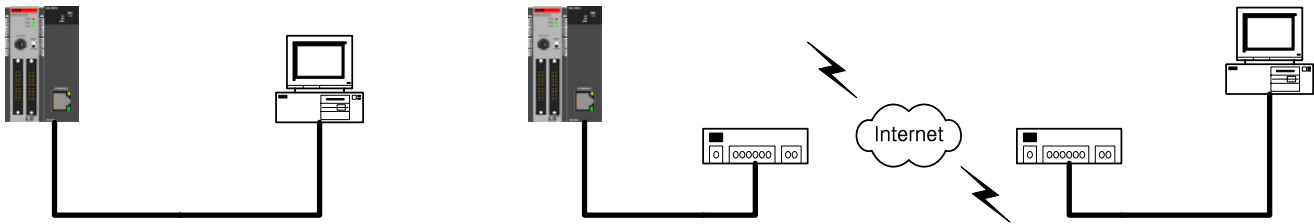

[Figure 4-3] Network configuration using XGB and MMI

Communication between XGB Fast Enet I/F module and PC is available to perform 1:1 communication by using cross cable or 1:N communication by connecting network. It provides connecting and data sending/receiving by using XG5000, XG-PD or MMI on PC. XG5000, XG-PD do download/upload parameter and program and furthermore these provide data sending/receiving by using the dedicated service, Modbus TCP/IP, user define frame.

4.2.4 Network configuration between LSIS modules

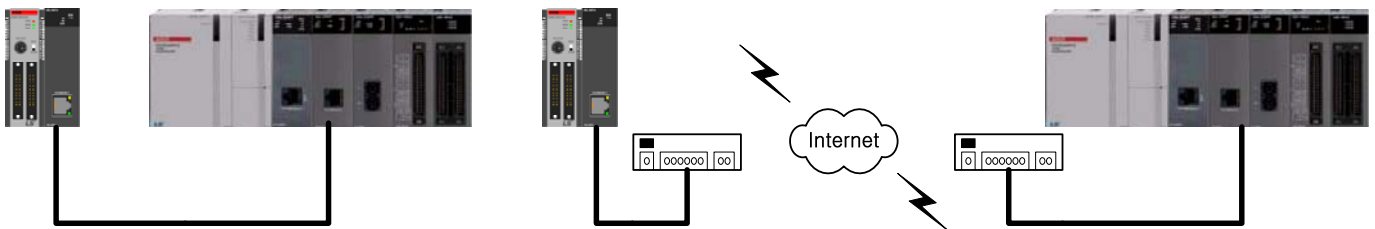

[Figure 4-4] Network configuration between LSIS modules

XGB Fast Enet I/F module and Enet I/F of XGT series provide system configuration. 1:1 communication is available using cross cable or 1:N communication is available by connecting network. It provides data sending/receiving by using main service, Modbus TCP/IP, user define frame.

4.2.5 Network configuration using XGB and other LSIS PLC

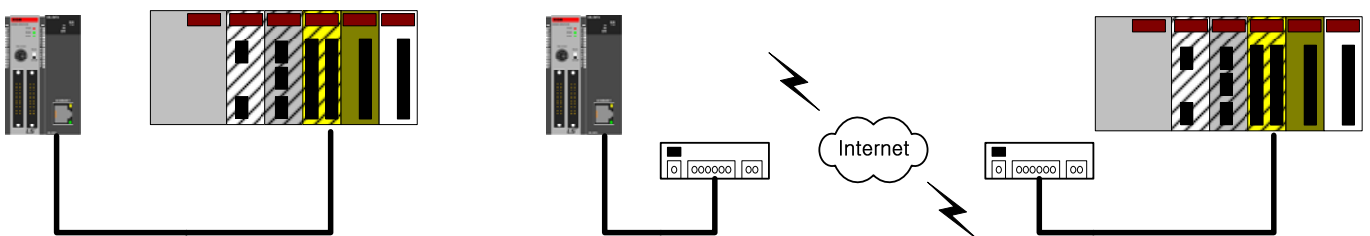

[Figure 4-5] Network configuration using XGB and other LSIS PLC

XGB Fast Enet I/F module provides communication with other LSIS PLC, HMI, MMI. . 1:1 communication is available using cross cable or 1:N communication is available by connecting network. To communicate, protocols between PLCs should be same.

Chapter 5 Protocols of Various Services

5.1 General

5.1.1 XGB Fast Enet I/F module protocol introduction

XGB Fast Enet I/F module supports open Ethernet. It provides network configuration that is to connect LSIS and other company PLC, PC on network.

To set IP, parameter of each PLC, protocol should be followed to do communicate after finishing network configuration. Supported protocols by XGB Fast Enet I/F module are XGT dedicated, Modbus TCP/IP, user define frame.

Each protocol supports server/client operation. Dedicated server and P2P function communicate according to the designated protocols.

5.1.2 Protocol by service

Each protocol's classified server/client by its function. [Table 5-1] shows protocol by service.

Item		Specification			
		Driver	Communication method	Port No.	Remark
Communication function	Dedicated	XGT server	TCP/IP	2004	<ul style="list-style-type: none"> ▪ Max. 4 channels ▪ Max. 512 bytes
			UDP/IP	2005	
		Modbus TCP server	TCP/IP	502	
	P2P	XGT client	TCP/IP	2004	<ul style="list-style-type: none"> ▪ Max. 3 channels ▪ Max. 32 blocks
			UDP/IP	2005	
		Modbus TCP client	TCP/IP	502	
		User define frame	TCP/IP	User's assignment	
			UDP/IP	User's assignment	

[Table 5-1] Protocols of various services

5.2 XGT Dedicated Protocol

5.2.1 General

XGT main protocol does communicate between LSIS Enet I/F modules. Read/write is available by instructions and communication is available on PC, HMI by using XGT dedicated protocol.

XGT dedicated communication is available in 2-ways communication method of TCP and UDP.

Protocol	Communication method	Port no.
XGT dedicated	TCP/IP	2004
	UDP/IP	2005

[Table 5-2] XGT main protocol

5.2.2 Frame structure

(1) XGT dedicated packet structure through Enet

During the period of communicating by using XGT dedicated protocol, it includes LSIS frame which includes MAC, IP header, TCP header and data for Enet communication.

[Fig. 5-1] shows XGT dedicated packet structure through Enet.

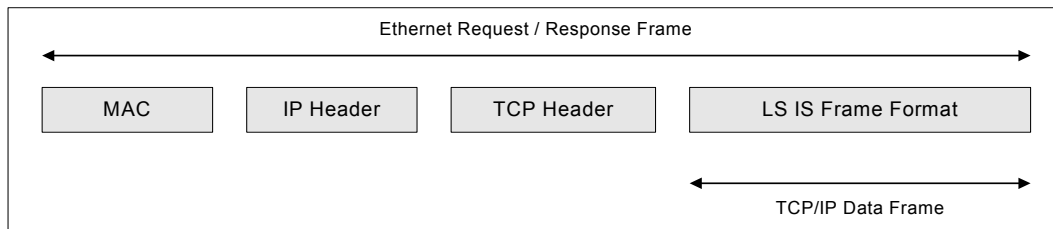

[Figure 5-1] XGT dedicated packet structure through Ethernet

(2) XGT dedicated frame structure

LSIS own frame for data communication includes LSIS ID, instruction, data type, data.

[Fig.5-2] shows XGT dedicated frame structure.

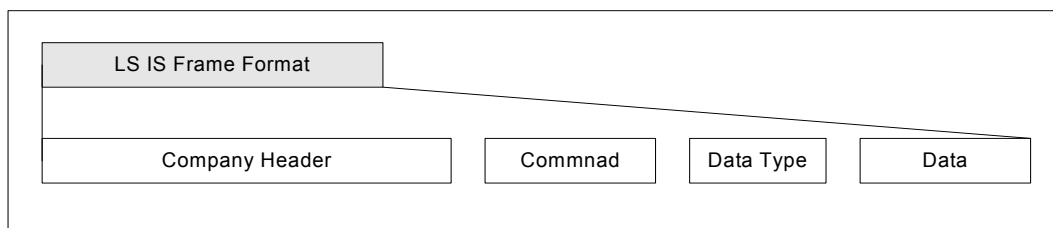

[Figure 5-2] XGT dedicated frame structure

5.2.3 XGT dedicated protocol data type

XGT dedicated protocol is available to take [Table. 5-3] data type.

Data type	Data code	Example
Bit	0x0000	%PX0,%LX0,%FX0
Byte	0x0100	%MB0,%PB0,%DB0
Word	0x0200	%PW0,%LW0,%FW0,%DW0
DWord	0x0300	%PD0,%LD0,%FD0,%DD0
LWord	0x0400	%PL0,%LL0,%FL0,%DL0
Continuous(Byte)	0x1400	-

[Table 5-3] XGT dedicated protocol data type

5.2.4 Instruction of XGT dedicated protocol

Using instructions of XGT dedicated protocol are 4 , each instruction does Read/Write, Request/Response.

In case of 'Individual', usable data types of each instruction are Bit, Byte, Word, DWord, LWord.

But for the 'Continuous', only Byte is usable.

Instruction	Instruction code	Data type	Treatment	
Read	Request : 0x5400	Individual	0x0000	Reads data by each data type
			0x0100	
			0x0200	
			0x0300	
			0x0400	
	Continuous	0x1400	Reads byte type variables in block unit	
	Response : 0x5500	Individual	0x0000	Responses to the request of Read data
			0x0100	
			0x0200	
			0x0300	
0x0400				
Continuous	0x1400	Response to the request of Read in block unit		
Write	Request : 0x5800	Individual	0x0000	Writes by each data type
			0x0100	
			0x0200	
			0x0300	
			0x0400	
	Continuous	0x1400	Read byte type variables in block unit	
	Response: 0x5900	Individual	0x0000	Responses to the request of Write data
			0x0100	
			0x0200	
			0x0300	
0x0400				
Continuous	0x1400	Responses to the request of Write in block unit		

[Table 5-4] Instruction of XGT dedicated protocol

5.2.5 Header and data structure of XGT dedicated protocol

(1) Header and data structure

[Table 5-5] shows LSIS Header, Instruction, Data Type, Data, which included in LSIS frame of XGT dedicated protocol.

Item	Client(Request frame)			Server(Response frame)		
	Classification	Content	Size	Classification	Content	Size
LSIS Header	LSIS ID	LSIS ID 1	10	LSIS ID	LSIS ID 1 LSIS ID 2	10
	PLC information	0x00~0xFF	2	PLC information	0x00~0xFF	2
	CPU information	0xA0	1	CPU information	0xA0	1
	Frame direction	0x33	1	Frame direction	0x11	1
	Frame order no.	0x0000~0xFFFF	2	Frame order no.	0x0000~0xFFFF	2
	Length	0x0000~0x0100	2	Length	0x0000~0x0100	2
	Position information	0x00~0xFF	1	Position information	0x00~0xFF	1
	Check sum	0x00~0xFF	1	Check sum	0x00~0xFF	1
Command	Instruction	0x5400	Read	Instruction	0x5500	Read
		0x5800	Write		0x5900	Write
Data Type	Data type	0x0000	Bit	Data type	0x0000	Bit
		0x0100	Byte		0x0100	Byte
		0x0200	Word		0x0200	Word
		0x0300	DWord		0x0300	DWord
		0x0400	LWord		0x0400	LWord
		0x1400	Continuous		0x1400	Continuous
Data	Reserved area	-	2	Reserved area	-	2
	Number of blocks	0x0100~0x1000	2	Error status	0x0000~0xFFFF	2
	Length of variables(N)	0x0400~0x1000	2	Data		2
	Data address	-	N			
	Number of data	0x0(M)00	M			

[Table 5-5] Header and data structure of XGT dedicated protocol

(2) LSIS ID

LSIS network uses 2 LSIS(LS Industrial Systems) IDs. LSIS ID 1 is for operation of XGT, XGB series as a client. In case of operating as a server, LSIS ID requested by a client, the client should use LSIS ID 1 or LSIS ID 2.

Classification	Format	Frame										Remark
		L	S	I	S	-	X	G	T	/n	/n	
LSIS ID 1	ASCII	L	S	I	S	-	X	G	T	/n	/n	XGT,XGB
	HEX	0x4C	0x53	0x49	0x53	0x2D	0x58	0x47	0x54	0x00	0x00	
LSIS ID 2	ASCII	L	G	I	S	-	G	L	O	F	A	GM,MK
	HEX	0x4C	0x47	0x49	0x53	0x2D	0x47	0x4C	0x4F	0x46	0x41	

[Table 5-6] LSIS ID

Chapter 5 Protocols of Various Services

5.2.6 Frame examples

(1) Request frame for individual reading of variables

Classification	Type	Frame										Size
Company ID	ASCII	L	S	I	S	-	X	G	T	/n	/n	10
	HEX	0x4C	0x53	0x49	0x53	0x2D	0x58	0x47	0x54	0x00	0x00	
	ASCII	L	G	I	S	-	G	L	O	F	A	
	HEX	0x4C	0x47	0x49	0x53	0x2D	0x47	0x4C	0x4F	0x46	0x41	
PLC Info.	HEX	0x00	0x00									2
CPU Info.		0xA0										1
Source of Frame		0x33										1
Invoked ID		0x00	0x01									2
Length		0x10	0x00									2
Position		0x00										1
Check Sum		0x09										1
Command		0x54	0x00									2
Data Type		0x14	0x00									2
Reserved		0x00	0x00									2
Block No.		0x01	0x00									2
Variable Length		0x04	0x00									2
Data Address	ASCII	%	M	B	0							4
	HEX	0x25	0x4D	0x42	0x30							
Data Count	HEX	0x02	0x00									2

[Table 5-7] Request frame for individual reading of variables

(2) Response frame for individual reading of variables

Classification	Type	Frame										Size
Company ID	ASCII	L	S	I	S	-	X	G	T	/n	/n	10
	HEX	0x4C	0x53	0x49	0x53	0x2D	0x58	0x47	0x54	0x00	0x00	
	ASCII	L	G	I	S	-	G	L	O	F	A	
	HEX	0x4C	0x47	0x49	0x53	0x2D	0x47	0x4C	0x4F	0x46	0x41	
PLC Info	HEX	0x02	0x08									2
CPU Info		0xA0										1
Source of Frame		0x11										1
Invoked ID		0x00	0x01									2
Length		0x0E	0x00									2
Position		0x01										1
Check Sum		0x25										1
Command		0x55	0x00									2
Data Type		0x14	0x00									2
Reserved		0x00	0x00									2
Error State		0x00	0x00									2
Block No.		0x10	0x00									2
Data Count		0x02	0x00									2
Data		0x00	0x00									2

[Table 5-8] Response frame for individual reading of variables

(3) Request frame for continuous reading of variables

Classification	Type	Frame										Size
Company ID	ASCII	L	S	I	S	-	X	G	T	/n	/n	10
	HEX	0x4C	0x53	0x49	0x53	0x2D	0x58	0x47	0x54	0x00	0x00	
	ASCII	L	G	I	S	-	G	L	O	F	A	
	HEX	0x4C	0x47	0x49	0x53	0x2D	0x47	0x4C	0x4F	0x46	0x41	
PLC Info.	HEX	0x00	0x00									2
CPU Info.		0xA0										1
Source of Frame		0x33										1
Invoked ID		0x00	0x01									2
Length		0x10	0x00									2
Position		0x00										1
Check Sum		0x09										1
Command		0x54	0x00									2
Data Type		0x14	0x00									2
Reserved		0x00	0x00									2
Block No.		0x01	0x00									2
Variable Length		0x04	0x00									2
Data Address	ASCII	%	M	B	0							4
	HEX	0x25	0x4D	0x42	0x30							
Data Count	HEX	0x02	0x00									2

[Table 5-9] Request frame for continuous reading of variables

(4) Response frame for continuous reading of variables

Classification	Type	Frame										Size
Company ID	ASCII	L	S	I	S	-	X	G	T	/n	/n	10
	HEX	0x4C	0x53	0x49	0x53	0x2D	0x58	0x47	0x54	0x00	0x00	
	ASCII	L	G	I	S	-	G	L	O	F	A	
	HEX	0x4C	0x47	0x49	0x53	0x2D	0x47	0x4C	0x4F	0x46	0x41	
PLC Info	HEX	0x02	0x08									2
CPU Info		0xA0										1
Source of Frame		0x11										1
Invoked ID		0x00	0x01									2
Length		0x0E	0x00									2
Position		0x01										1
Check Sum		0x25										1
Command		0x55	0x00									2
Data Type		0x14	0x00									2
Reserved		0x00	0x00									2
Error State		0x00	0x00									2
Block No.		0x10	0x00									2
Data Count		0x02	0x00									2
Data		0x00	0x00									2

[Table 5-10] Response frame for continuous reading of variables

5.3 Modbus TCP/IP Protocol

5.3.1 General

Modbus TCP/IP protocol function is to data Read/Write by using function codes. Modbus TCP/IP frame is composed of MAC, IP Header, TCP Header, Modbus ADU for Enet communication.

- (1) ADU : Application Data Unit
- (2) MBAP : MODBUS Application Protocol
- (3) PDU : Protocol Data Unit

5.3.2 Structure of Modbus TCP/IP frame

(1) Structure of Modbus TCP/IP frame through Enet

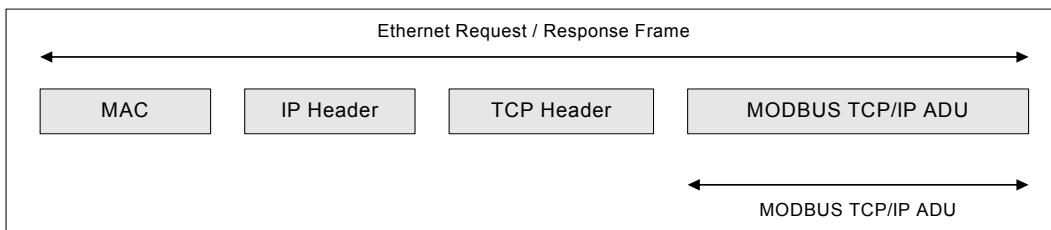

[Figure 5-3] Structure of Modbus TCP/IP frame through Enet

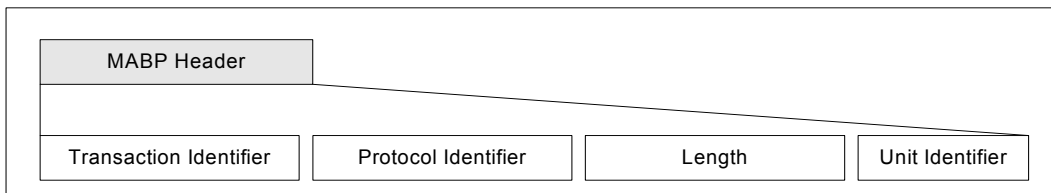

[Figure 5-4] Structure of Modbus TCP/IP ADU

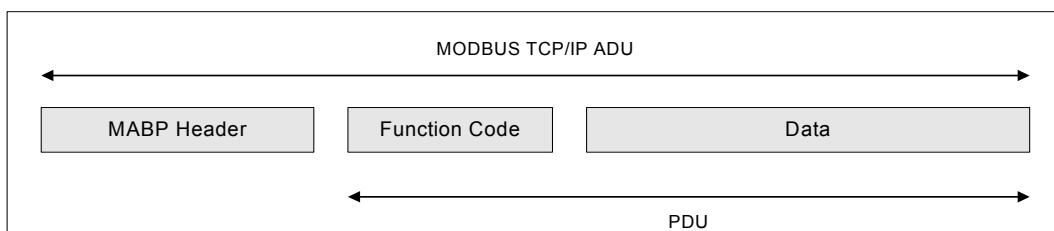

[Figure 5-5] Structure of Modbus ADU

5.3.3 MBAP Header structure

Classification	Size	Description	Client	Server
Transaction Identifier	2 bytes	MODBUS Request/ Response treatment	Initializing	Response repeatedly if server responses
Protocol Identifier	2 bytes	0 = MODBUS protocol	Initializing	Reproducing it from request frame if server responses
	2 bytes	Frame size except MBAP	Making (If requested)	Server makes it (If it responses)
Unit Identifier	1byte	Classification of unit which connected to serial line	Initializing	Reproducing it from request frame if server responses

[Table 5-11] MBAP Header structure

5.3.4 Available function code

Classification	Function	Modbus mark
Function Code 01 (0x01)	Read output bit	Read Coils
Function Code 02 (0x02)	Read input bit	Read Discrete Inputs
Function Code 03 (0x03)	Read output word	Read Holding Registers
Function Code 04 (0x04)	Read input word	Write Input Register
Function Code 05 (0x05)	Write output bit	Write single Coil
Function Code 15 (0x0F)	Continuously write output bit	Write Multiple Coils
Function Code 16 (0x10)	Continuously write output word	Write Multiple Registers

[Table 5-12] Available function code

5.3.5 Frame structure by function code

(1) Function code 0x01: Read Coils

(a) Request

Classification	Size	Range
Function code	1 byte	0x01
Start address	2 bytes	0x0000 ~ 0xFFFF
Number of coils	2 bytes	0x0001 ~ 0x07D0 (2000 bits)

[Table 5-13] Function code 0x01 request frame

(b) Response

Classification	Size	Range
Function code	1 byte	0x01
Number of bytes	2 bytes	N
Coil status	n byte	n = N or N + 1

[Table 5-14] Function code 0x01 response frame

Chapter 5 Protocols of Various Services

(c) Error

Classification	Size	Range
Function code	1 byte	0x81 (Function code + 0x80)
Exception code	1 byte	0x01,0x02,0x03,0x04

[Table 5-15] Function code 0x01 error frame

(d) Examples

Request frame		Response frame	
Classification	HEX	Classification	HEX
Function code	0x01	Function code	0x01
Start address (Upper byte)	0x00	Number of bytes	0x03
Start address (Lower byte)	0x13	Coil status (27-20)	0xCD
Number of coils (Upper byte)	0x00	Coil status (36-28)	0x6B
Number of coils (Lower byte)	0x13	Coil status (38-36)	0x05

[Table 5-16] Function code 0x01 frame examples

(2) Function code 0x02: Read input bit (Read Discrete Inputs)

(a) Request

Classification	Size	Range
Function code	1 byte	0x02
Start address	2 bytes	0x0000 ~ 0xFFFF
Number of input	2 bytes	0x0001 ~ 0x07D0 (2000 bits)

[Table 5-17] Function code 0x02 request frame

(b) Response

Classification	Size	Range
Function code	1 byte	0x01
Number of bytes	2 bytes	N
Input status	N x 1 bytes	-

[Table 5-18] Function code 0x02 response frame

(c) Error

Classification	Size	Range
Function code	1 byte	0x82 (Function code + 0x80)
Exception code	1 bytes	0x01,0x02,0x03,0x04

[Table 5-19] Function code 0x02 response frame

(d) Examples

Request frame		Response frame	
Classification	HEX	Classification	HEX
Function code	0x02	Function code	0x01
Start address (Upper byte)	0x00	Number of bytes	0x03
Start address (Lower byte)	0xC4	Coil status (27-20)	0xCD
Input status (Upper byte)	0x00	Coil status (36-28)	0x6B
Number of coils (Lower byte)	0x16	Coil status (38-36)	0x05

[Table 5-20] Function code 0x02 request frame examples

(3) Function code 0x03: Read Holding Registers

(a) Request

Classification	Size	Range
Function code	1 byte	0x03
Start address	2 bytes	0x0000 ~ 0xFFFF
Number of input	2 bytes	0x0001 ~ 0x007D (125 words)

[Table 5-21] Function code 0x03 request frame

(b) Response

Classification	Size	Range
Function code	1 byte	0x01
Number of bytes	2 bytes	2 x N
Input status	N x 2 bytes	-

[Table 5-22] Function code 0x03 response frame

(c) Error

Classification	Size	Range
Function code	1 byte	0x83 (Function code + 0x80)
Exception code	1 byte	0x01,0x02,0x03,0x04

[Table 5-23] Function code 0x03 error frame

(d) Examples

Request frame		Response frame	
Classification	HEX	Classification	HEX
Function code	0x03	Function code	0x03
Start address (Upper byte)	0x00	Number of bytes	0x06
Start address (Lower byte)	0x6B	Word status (108)	0x02
Number of words (Upper byte)	0x00	Word status (108)	0x2B
Number of words (Lower byte)	0x03	Word status (109)	0x00
		Word status (109)	0x00
		Word status (110)	0x00
		Word status (110)	0x64

[Table 5-24] Function code 0x03 frame examples

(4) Function code 0x04: Read Input Registers

(a) Request

Classification	Size	Range
Function code	1 byte	0x04
Start address	2 bytes	0x0000 ~ 0xFFFF
Number of input	2 bytes	0x0001 ~ 0x007D (125 words)

[Table 5-25] Function code 0x04 request frame

(b) Response

Classification	Size	Range
Function code	1 byte	0x04
Number of byte	2 bytes	2 x N
Input status	N x 2 bytes	-

[Table 5-26] Function code 0x04 response frame

Chapter 5 Protocols of Various Services

(c) Error

Classification	Size	Range
Function code	1 byte	0x84 (Function code + 0x80)
Exception code	1 byte	0x01,0x02,0x03,0x04

[Table 5-27] Function code 0x04 error frame

(d) Examples

Request frame		Response frame	
Classification	HEX	Classification	HEX
Function code	0x04	Function code	0x04
Start address (Upper byte)	0x00	Number of bytes	0x02
Start address (Lower byte)	0x08	Word status (108)	0x00
Number of words (Upper byte)	0x00	Word status (108)	0x0A
Number of words (Lower byte)	0x01		

[Table 5-28] Function code 0x04 frame examples

(5) Function code 0x05: Write Single Coil

(a) Request

Classification	Size	Range
Function code	1 byte	0x05
Start address	2 bytes	0x0000 ~ 0xFFFF
Input value	2 bytes	0x0000 or 0xFF0D

[Table 5-29] Function code 0x05 request frame

(b) Response

Classification	Size	Range
Function code	1 byte	0x05
Number of bytes	2 bytes	0x0000 ~ 0xFFFF
Input status	2 bytes	0x0000 or 0xFF00

[Table 5-30] Function code 0x05 response frame

(c) Error

Classification	Size	Range
Function code	1 byte	0x85 (Function code + 0x80)
Exception code	1 byte	0x01,0x02,0x03,0x04

[Table 5-31] Function code 0x05 error frame

(d) Examples

Request frame		Response frame	
Classification	HEX	Classification	HEX
Function code	0x02	Function code	0x01
Start address (Upper byte)	0x00	Number of bytes	0x03
Start address (Lower byte)	0xC4	Coil status (27-20)	0xCD
Input status (Upper byte)	0x00	Coil status (36-28)	0x6B
Number of coils (Lower byte)	0x16	Coil status (38-36)	0x05

[Table 5-32] Function code 0x05 frame examples

(6) Function code 0x0F: Write Multiple Registers

(a) Request

Classification	Size	Range
Function code	1 byte	0x0F
Start address	2 bytes	0x0000 ~ 0xFFFF
Number of output	2 bytes	0x0001 ~ 0x07BD
Number of bytes	1 byte	N
Output value	N x 1 byte	

[Table 5-33] Function code 0x0F request frame

(b) Response

Classification	Size	Range
Function code	1 byte	0x0F
Number of bytes	2 bytes	0x0000 ~ 0xFFFF
Input status	2 bytes	0x0001 ~ 0x07B0

[Table 5-34] Function code 0x0F response frame

(c) Error

Classification	Size	Range
Function code	1 byte	0x8F (Function code + 0x80)
Exception code	1 byte	0x01,0x02,0x03,0x04

[Table 5-35] Function code 0x0F request frame

(d) Examples

Request frame		Response frame	
Classification	HEX	Classification	HEX
Function code	0x0F	Function code	0x0F
Start address (Upper byte)	0x00	Start address (Upper byte)	0x00
Start address (Lower byte)	0x13	Start address (Lower byte)	0x13
Number of output (Upper byte)	0x00	Number of output(Upper byte)	0x00
Number of output (Lower byte)	0x0A	Number of output(Lower byte)	0x0A
Number of bytes	0x02		
Output value (Upper byte)	0xCD		
Output value (Lower byte)	0x01		

[Table 5-36] Function code 0x01 request frame examples

(7) Function code 0x06: Write Single Register

(a) Request

Classification	Size	Range
Function code	1 byte	0x06
Start address	2 bytes	0x0000 ~ 0xFFFF
Output value	2 bytes	0x0000 or 0xFFFF

[Table 5-37] Function code 0x06 request frame

Chapter 5 Protocols of Various Services

(b) Response

Classification	Size	Range
Function code	1 byte	0x06
Start address	2 bytes	0x0000 ~ 0xFFFF
Output value	2 bytes	0x0000 or 0xFFFF

[Table 5-38] Function code 0x06 response frame

(c) Error

Classification	Size	Range
Function code	1 byte	0x86 (Function code + 0x80)
Exception code	1 byte	0x01,0x02,0x03,0x04

[Table 5-39] Function code 0x06 error frame

(d) Examples

Request frame		Response frame	
Classification	HEX	Classification	HEX
Function code	0x06	Function code	0x06
Start address (Upper byte)	0x00	Number of bytes	0x00
Start address (Lower byte)	0x01	Coil status (27-20)	0x01
Input status (Upper byte)	0x00	Coil status (36-28)	0x00
Number of coils(Lower byte)	0x03	Coil status (38-36)	0x03

[Table 5-40] Function code 0x06 frame examples

(8) Function code 0x10: Write Multiple Registers

(a) Request

Classification	Size	Range
Function code	1 byte	0x10
Start address	2 bytes	0x0000 ~ 0xFFFF
Number of output	2 bytes	0x0001 or 0x07D8
Number of bytes	1 byte	2 x N
Output value	N x 2 bytes	value

[Table 5-41] Function code 0x10 request frame

(b) Response

Classification	Size	Range
Function code	1 byte	0x10
Number of bytes	2 bytes	0x0000 ~ 0xFFFF
Number of output	2 bytes	0x0001 ~ 0x007B

[Table 5-42] Function code 0x01 response frame

(c) Error

Classification	Size	Range
Function code	1 byte	0x90 (Function code + 0x80)
Exception code	1 byte	0x01,0x02,0x03,0x04

[Table 5-43] Function code 0x10 error frame

(d) Examples

Request frame		Response frame	
Classification	HEX	Classification	HEX
Function code	0x10	Function code	0x01
Start address (Upper byte)	0x00	Start address (Upper byte)	0x00
Start address (Lower byte)	0x01	Start address (Lower byte)	0x01
Number of output (Upper byte)	0x00	Number of output (Upper byte)	0x00
Number of output (Lower byte)	0x02	Number of output (Lower byte)	0x02
Number of bytes	0x04		
Output value (Upper byte)	0x00		
Output value (Lower byte)	0x0A		
Output value (Upper byte)	0x01		
Output value (Lower byte)	0x02		

[Table 5-44] Function code 0x10 frame examples

Chapter 6 Dedicated Service

6.1 Dedicated Service Function Introduction

6.1.1 Server model

Dedicated service provides a server function as [Fig.6-1] Client/Server model. It operates data Read/Write by the protocol that the client connects and sets.

(1) Client/ Server model

Server does perform the function of ② Indication and ③ Response.

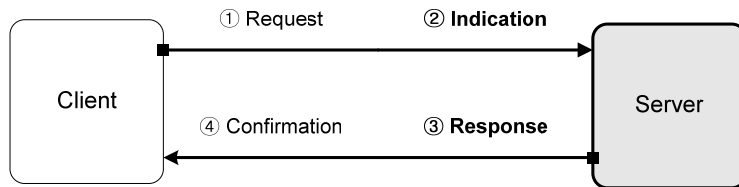

[Figure 6-1] Client/ Server model

6.1.2 System configuration

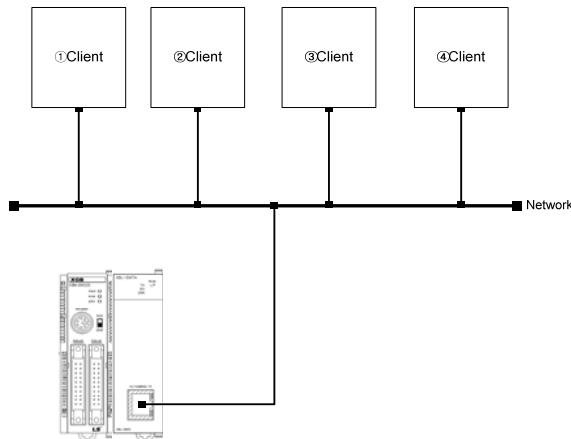

[Figure 6-2] Client/ Server system configuration

6.1.3 Dedicated service classification

Classification		Port no.	Protocol classification	Min./Max. connection numbers
XGT server	TCP XGT server	2004	TCP	1/4
	UDP XGT server	2005	UDP	1/4
Modbus TCP/IP server		502	TCP	1/4

[Table 6-1] Dedicated service classification

6.2 Setting Dedicated Service

6.2.1 Basic parameter

(1) Setting basic parameter in XG-PD

Open XG-PD. Then, select slot that installed XBL-EMTA on project window. Double-click the slot.

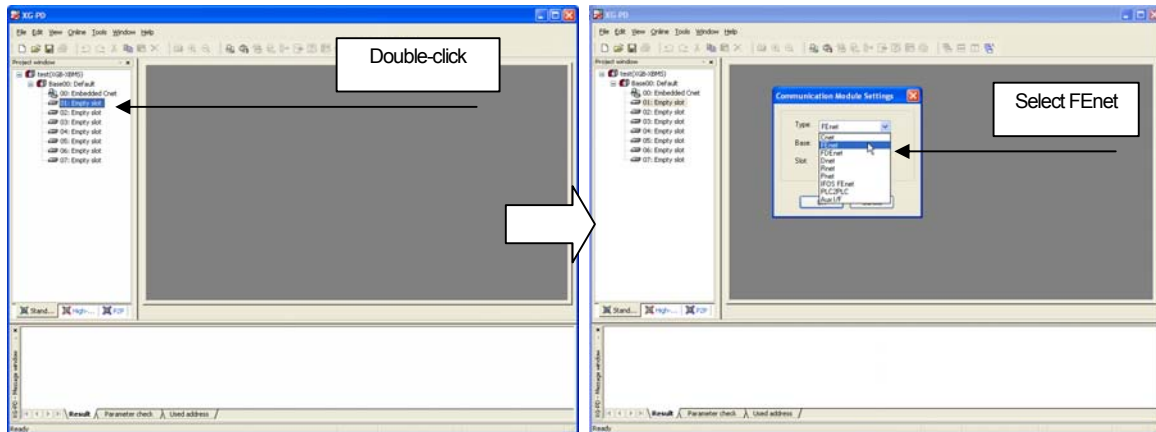

[Figure 6-3] Selecting basic parameter and setting communication module

Double-clicking shows 'communication module setting window'. Select FENet from communication modules, then click enter key. Finally, it shows the window as below [Fig. 6-4] Setting FENet .

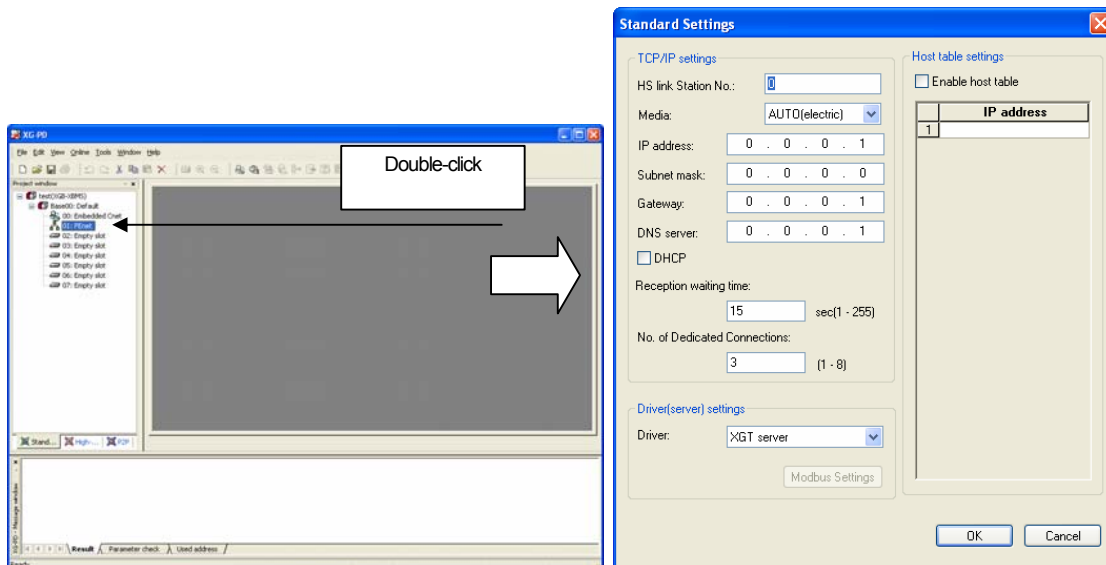

[Figure 6-4] Setting basic parameter

Double-clicking FENet shows the basic setting window as below [Fig.6-5].

Chapter6 Dedicated Service

(2) Basic setting

- (a) Receiving stand-by time is by the time of disconnection without the client's request.
- (b) Number of dedicated connection is the number of connecting clients. Up to 4 is available.
- (c) Number of channels of P2P is 4-dedicated connection numbers.
- (d) Setting driver (server) can be done by XGT server or Modbus TCP/IP
- (e) Server operates by the setting driver protocol.
- (f) Setting host table assign client IP.
- (g) Setting check box of enable host table makes connection only to registered IP.

6.3 XGT Server

6.3.1 TCP XGT server

TCP XGT server operates as below [Fig.6-5] TCP XGT server operation flow.

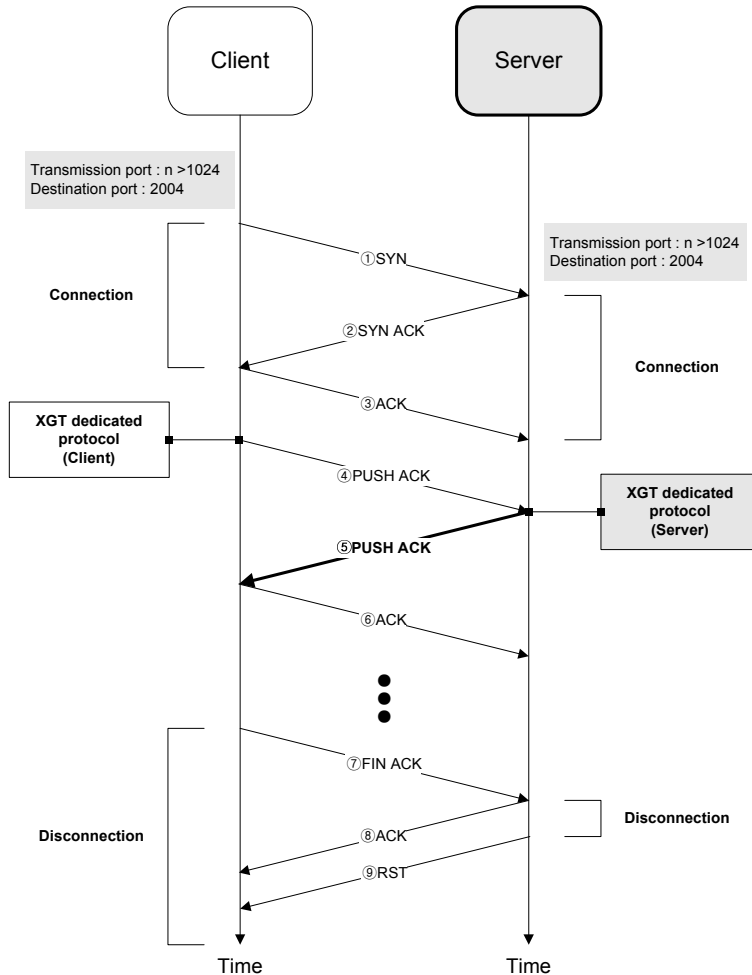

[Figure 6-5] TCP XGT server operation flow

(1) Connection

- (a) Client does transmit ① SYN to serve. Server does ② SYNACK.
- (b) Connection port no. is XGT dedicated protocol port no. 2004.
- (c) Client does connection check response ③ ACK.
- (d) Finishing ①~③ makes client/server connection.

(2) TCP XGT server

- (a) After connection, client does transmit ④ PUSH ACK according to XGT dedicated protocol.
- (b) Server does transmit ⑤ PUSH ACK for PUSH ACK Frame.
- (c) Client does transmit ⑥ ACK.

(3) Disconnection

- (a) Client does transmit ⑦ DISCONNECTION.
- (b) Server does transmit ⑧ RST and disconnect.

6.4 Modbus TCP/IP Server

Modbus TCP/IP server operates as below [Fig.6-6] Modbus TCP/IP Server operation flow.

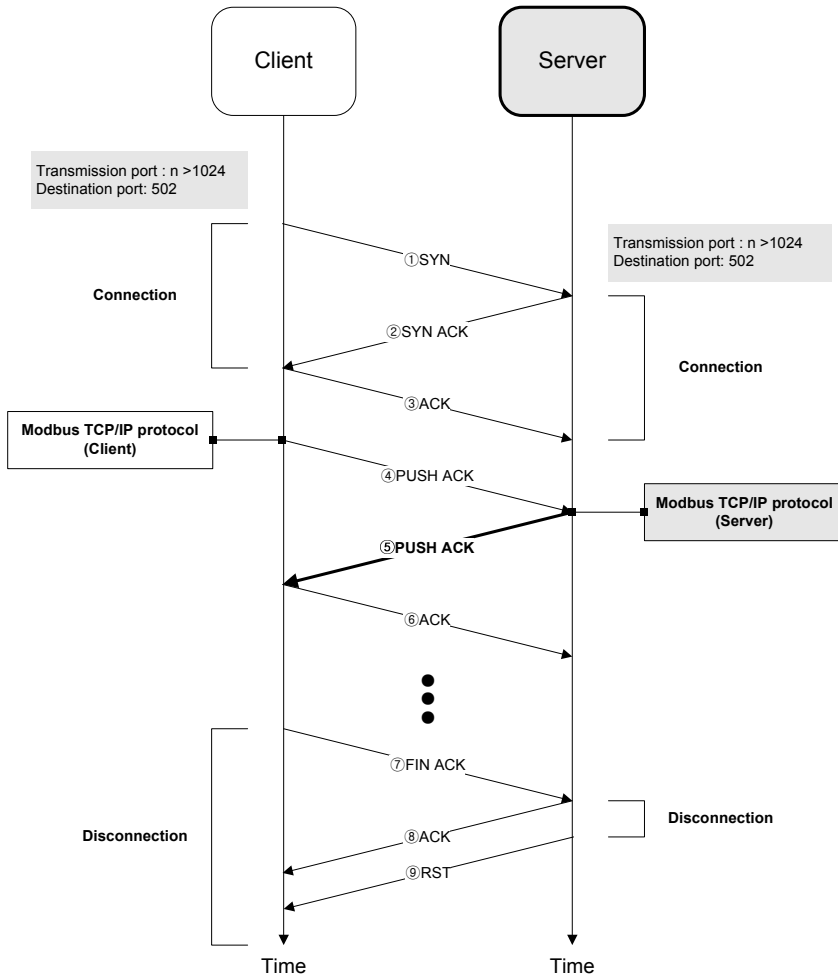

[Figure 6-6] Modbus TCP/IP Server operation flow

(4) Connection

- (a) Client does transmit ① SYN to serve. Server does ② SYN ACK.
- (b) Connection port no. is XGT dedicated protocol port no. 502.
- (c) Client does connection check response ③ ACK.
- (d) Finishing ①~③ makes client/server connection.

(5) TCP XGT client

- (a) After connection, client does transmit ④ PUSH ACK according to XGT dedicated protocol.
- (b) Server does transmit ⑤ PUSH ACK for PUSH ACK Frame.
- (c) Client does transmit ⑥ ACK.

(6) Disconnection

- (a) Client does transmit ⑦ DISCONNECTION.
- (b) Server does transmit ⑧ RST and disconnect.

Chapter 7 P2P Service

7.1 P2P Service Function Introduction

7.1.1 Client model

P2P service provides a client function as below [Fig.7-1] Client/Server model.

It requests data Read/Write to server. When each block operation status is ON, it provides the function of connecting request frame to the right channel and receiving response.

XGB Fast Enet I/F module communicates through Max.3 channels, each channel communicates by using different protocols.

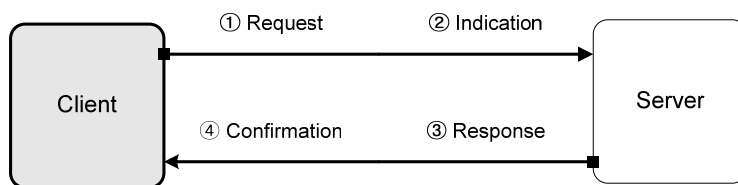

[Fig. 7-1] Client/Server model

Server executes ① Request and ④ Confirmation.

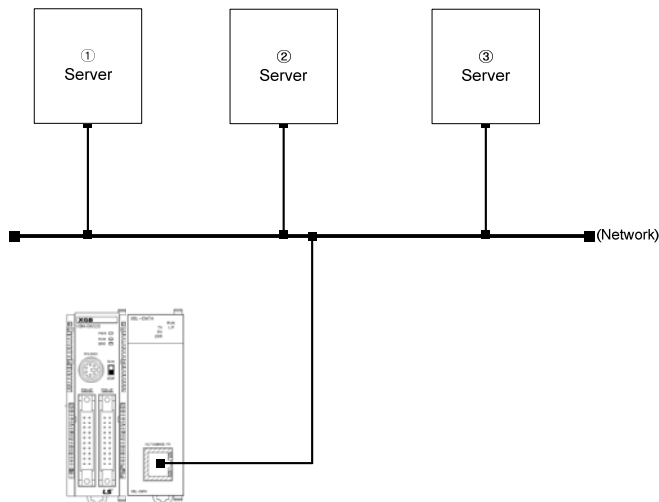

[Fig. 7-2] Client/Server system configuration

XBL-EMTA is available to connect Max. 3 servers as [Fig 7-2].

7.2 Setting P2P Service

7.2.1 Setting P2P parameter

(1) Setting communication module

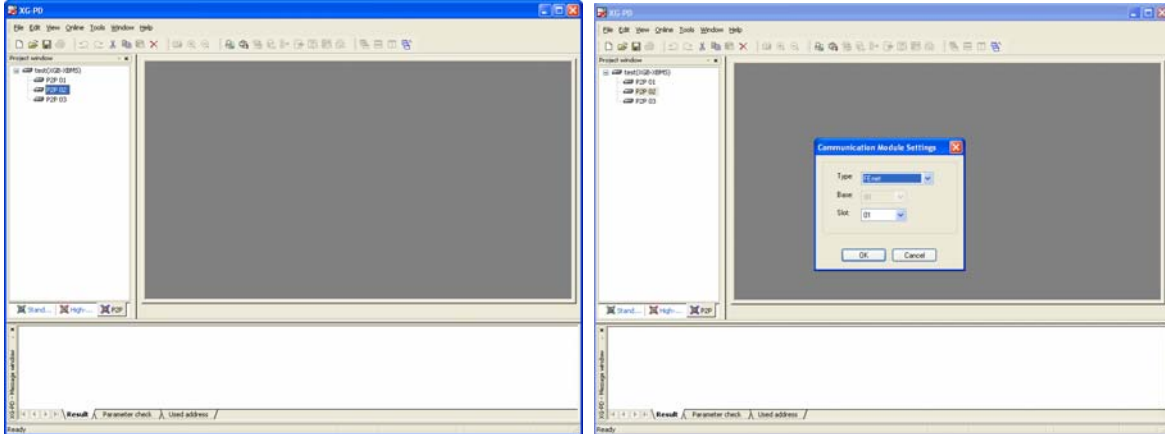

[Fig. 7-3] Communication module setting screen in P2Pparameter

- (a) As the left part of [Fig.7-3] project screen, select P2P02 or P2P03, double-click it.
- (b) P2P01 is a setting value of XGB CPU internal communication. It's fixed as Cnet.
- (c) Double-clicking shows communication setting screen as the right part of [Fig.7-3].
- (d) Set FENet in types.
- (e) Base is fixed as 00.
- (f) Slot is 01~07. Set it by the installation sequence of XBL-EMTA.
- (g) After finishing setting communication module, click enter key.
- (h) Clicking enter key shows detailed item of P2P as [Fig.7-4].

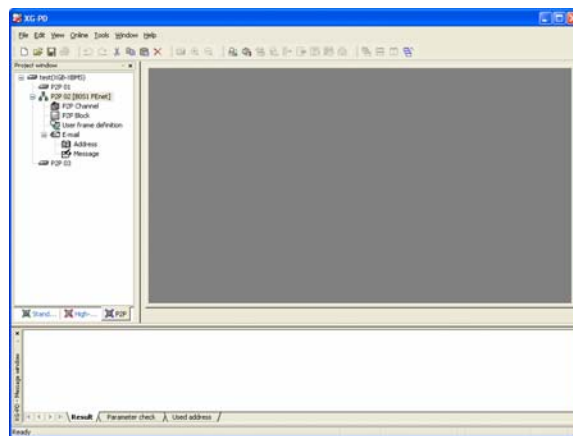

[Fig. 7-4] Finishing setting communication module in P2P parameter

(2) Setting channel

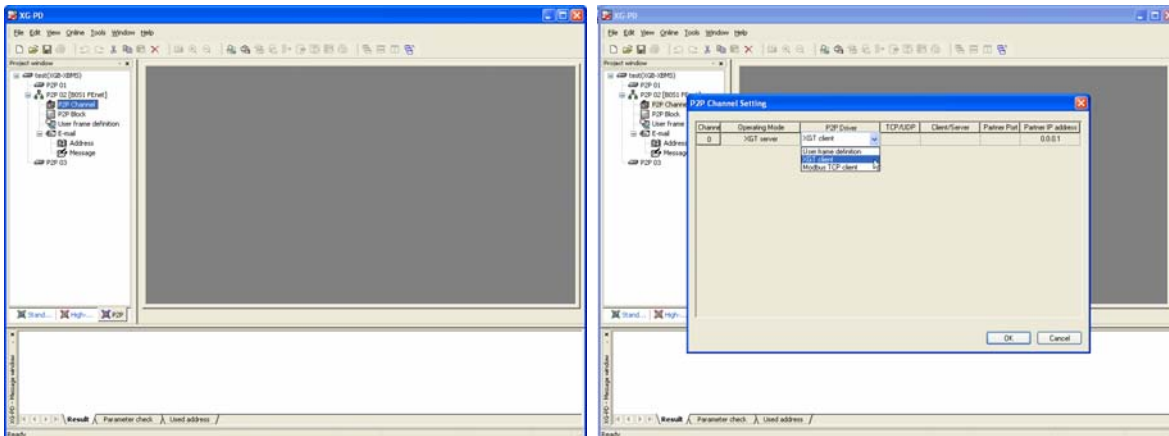

[Fig. 7-5] P2P channel setting screen

- (a) As the left screen of [Fig.7-5] project screen, select P2P channel, double-click it.
- (b) Double-clicking shows P2P channel setting screen as the right part of [Fig. 7-5].
- (c) Select the desired driver by clicking the arrow icon of P2P driver on P2P channel setting screen.
- (d) Select driver
 - (1) XGT client
 - (a) In case of assigning XGT client, TCP/UDP should be selected.
 - (b) Selecting TCP assigns port no. 2004. Selecting UDP assigns port no.2005.
 - (c) Write the destination IP address.
 - (2) Modbus TCP client
 - (a) Selecting Modbus client fixes port no.502.
 - (b) Write the destination IP address.
 - (3) User define frame
 - (a) In case of assigning user define frame, communication type should be selected as TCP/UDP.
 - (b) Select Client/Server in operation mode.
 - (c) Write the desired port no.
 - (d) Write the destination IP address.

[Fig.7-6] is an example that setting P2P on 3 channels.

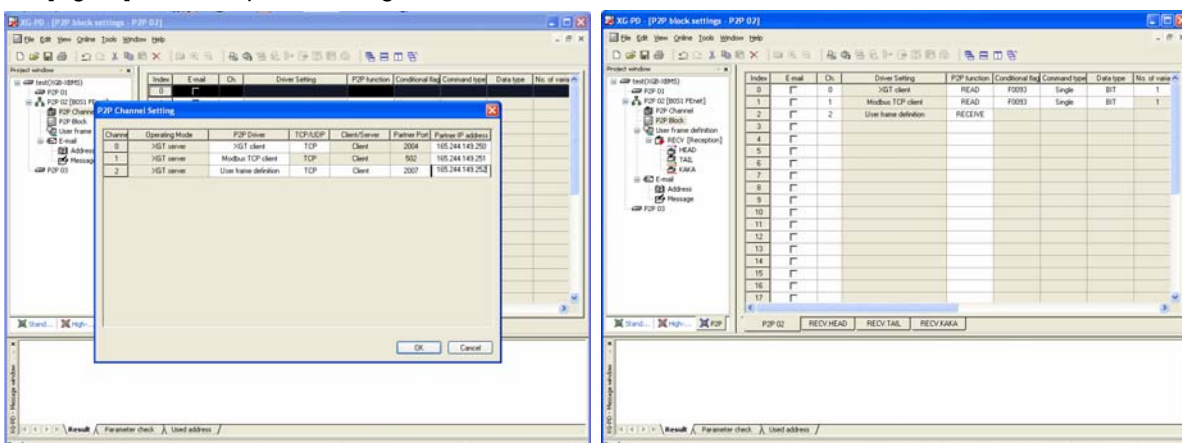

[Fig. 7-6] Example of setting P2P

Chapter 7 P2P Service

(6) Setting P2P block

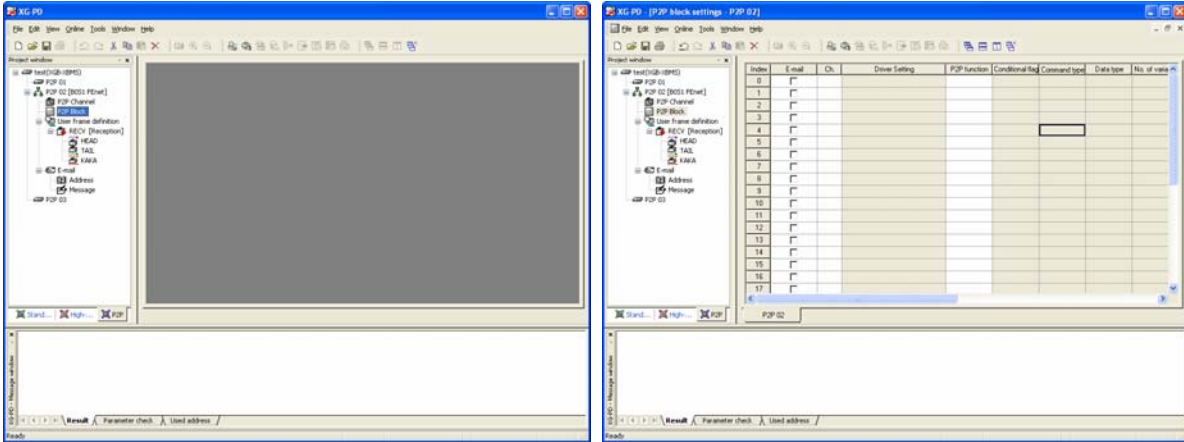

[Fig. 7-7] P2P block setting screen

- (a) After finishing setting channels, select P2P block on the project screen as the left screen of [Fig.7-7], double-click it.
- (b) Double-clicking shows block setting screen as the right screen of [Fig.7-7].

(7) Setting P2P block channel

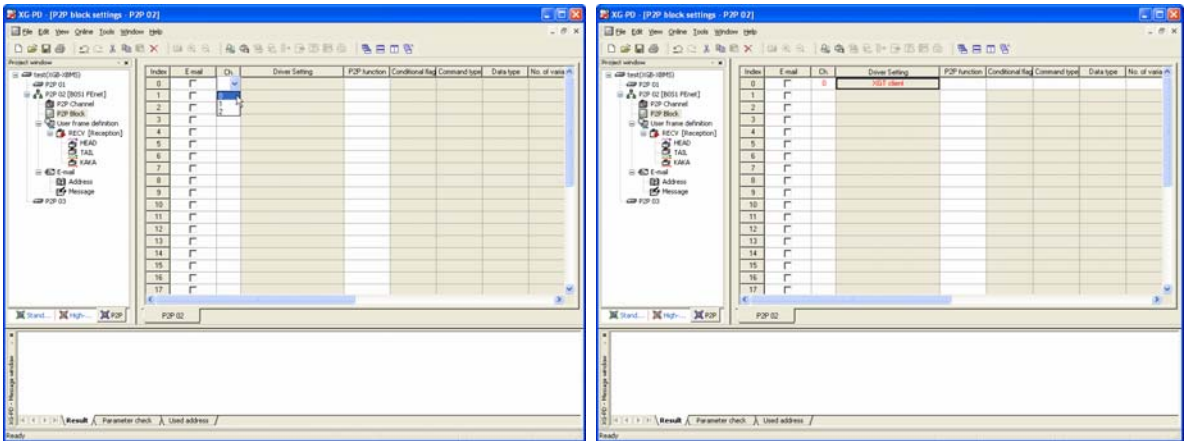

[Fig. 7-8] Setting P2P block channel

- (a) Assign each block channel as the left screen of [Fig. 7-8]. Select one from registered channels (0~3).
- (b) Assigning the desired channel as the right screen of [Fig. 7-8] saves assigned driver on setting channel.

(8) Setting P2P block driver

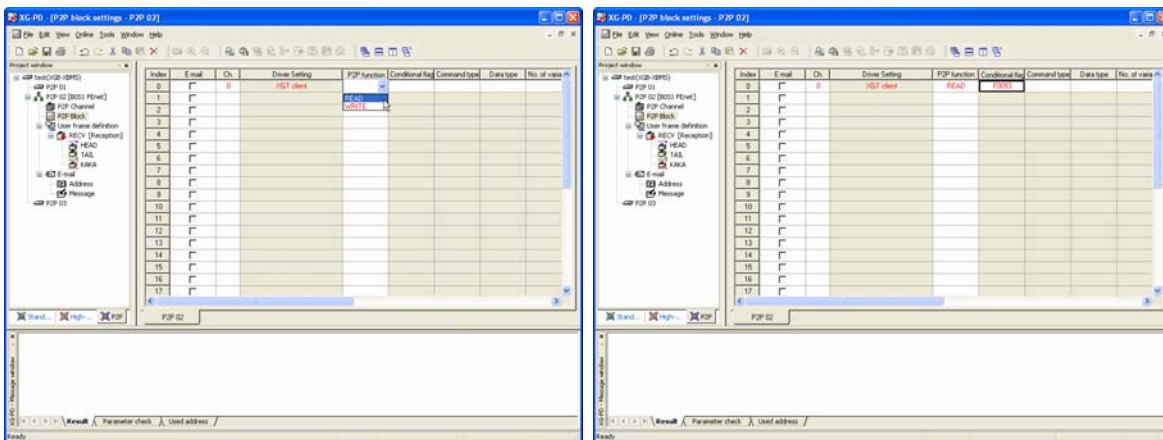

[Fig. 7-9] Setting P2P block function and operation condition

- (a) Select P2P function as the left screen of [Fig. 7-9]. Function can be selected by the assigned channel driver.
- (b) Client selects READ/WRITE.
- (c) Modbus TCP client selects READ/WRITE.
- (d) User define frame selects SEND/RECEIVE.
- (e) Write operation condition as the right screen of [Fig. 7-9]. Operation condition is an internal device of XGB CPU

(9) Setting P2P block type

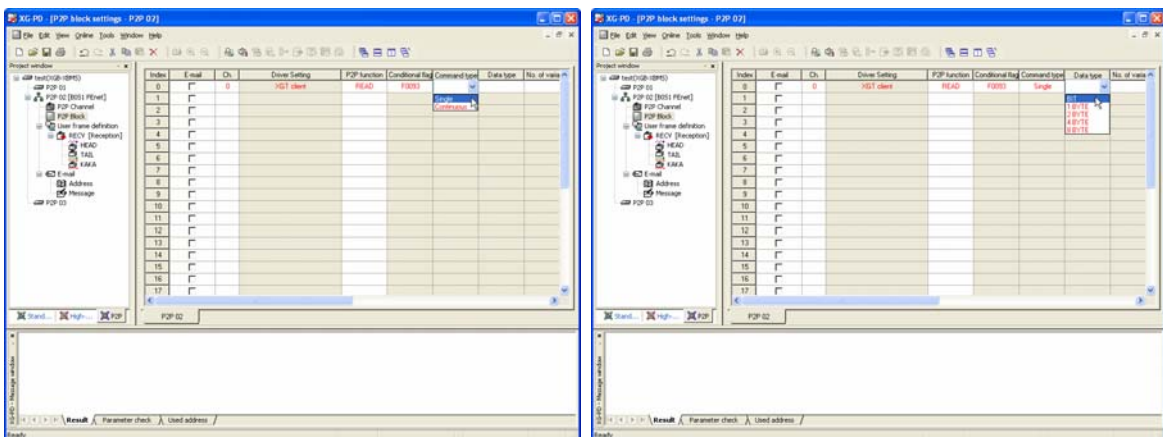

[Fig 7-10] Setting P2P block type and data type

- (a) Select the type as the left screen of [Fig. 7-10]. Function can be selected by the assigned channel driver.
- (b) XGT client selects SINGLE/CONTINUOUS.
- (c) Modbus TCP client selects SINGLE/CONTINUOUS.
- (d) User define frame can not select types.
- (e) Write operation condition as the left screen of [Fig. 7-10]. Operation condition is an internal device of XGB CPU

Chapter 7 P2P Service

(10) Setting number of P2P block variables

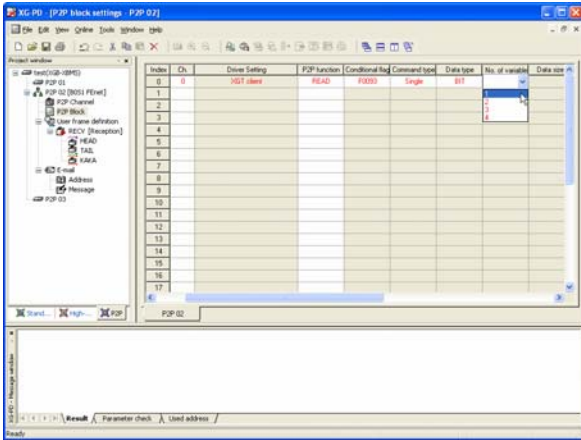

[Fig. 7-11] Setting number of P2P block variables

- Set number of variables as [Fig. 7-11].
- XGT client selects SINGLE/CONTINUOUS.
- Modbus TCP client is fixed as 1.
- User define frame can not select types.

(11) Setting P2P block variables

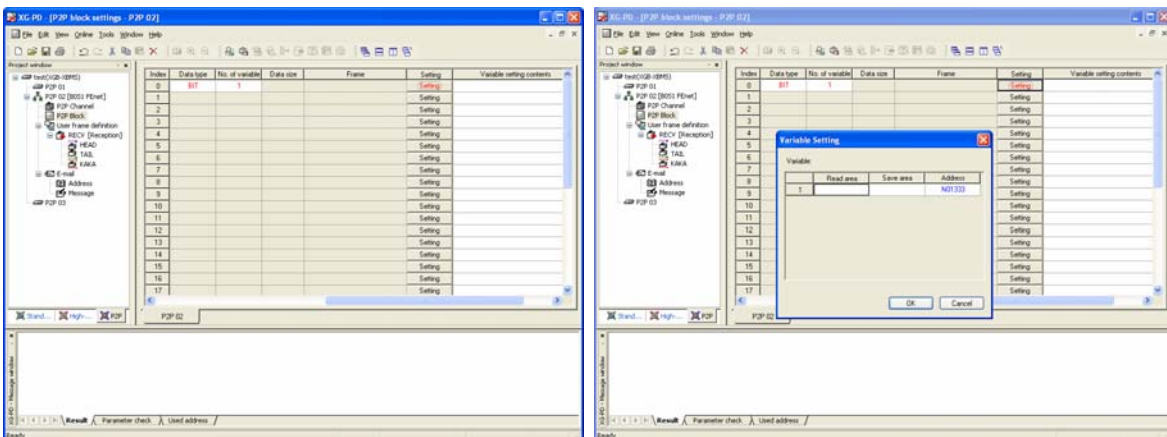

[Fig. 7-12] Setting P2P block variables

- Select the variable as the left screen of [Fig. 7-12]. Double-click it.
- Double-clicking shows the screen of setting variables as the right screen of [Fig. 7-12].
- Write can be 1~4 variables by the setting numbers of variables.

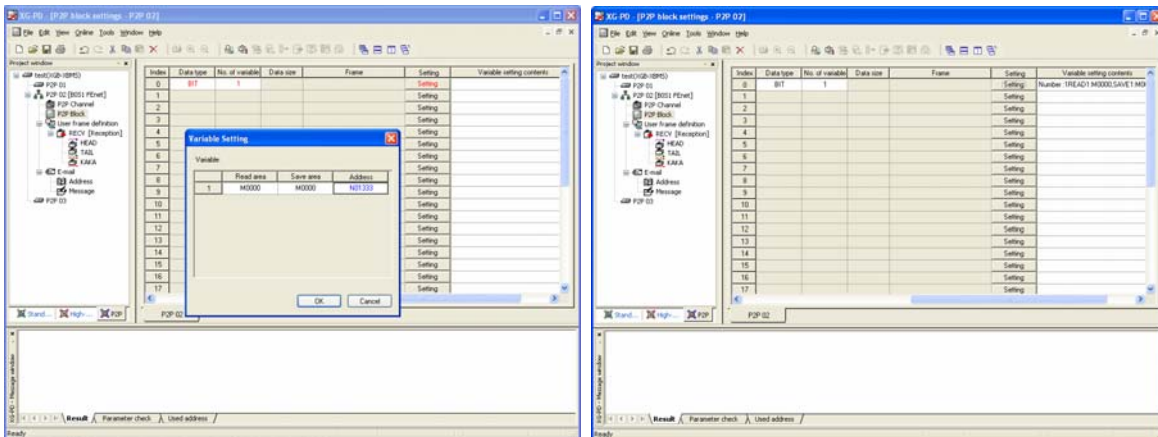

[Fig. 7-13] Finishing setting P2P block variables and setting block

- (d) Write read area/save area of XGB CPU as the left screen of [Fig. 7-13].
- (e) Clicking enter key finishes setting block as [Fig. 8-11].

7.2.2 Enable link

- (1) P2P enable setting screen

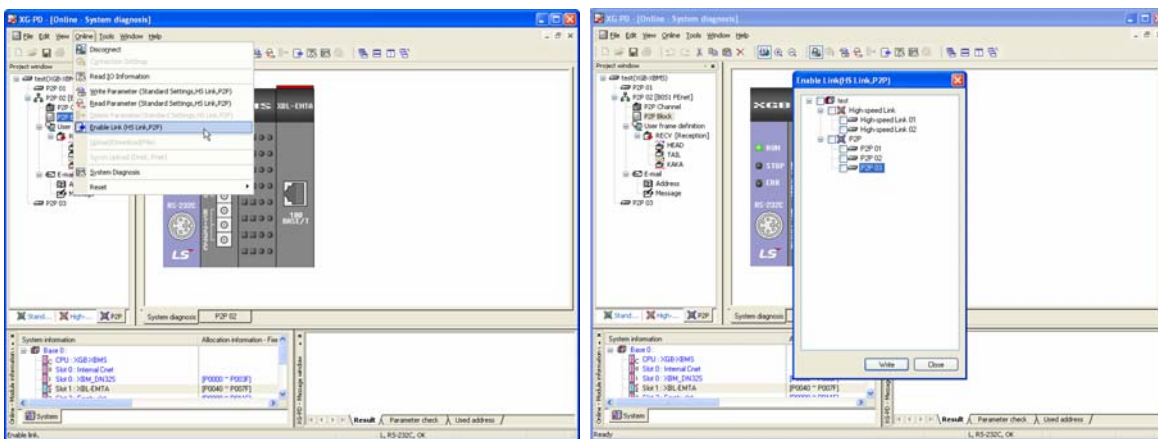

[Fig. 7-14] P2P enable setting screen

- (a) After setting P2P function, P2P enable should be set to start P2P service.
- (b) Connect XG-PD as the left screen of [Fig. 7-14], Select enable link on Online menu.
- (c) It shows enable link screen as the right screen of [Fig. 7-14].

Chapter 7 P2P Service

(2) P2P enable

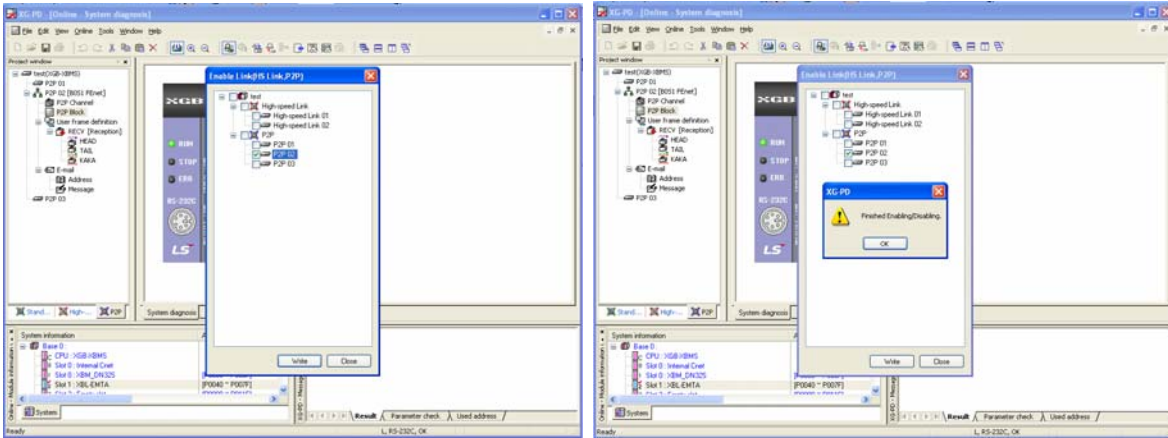

[Fig. 7-15] P2P enable

- (a) Select the desired P2P check box as the left screen of [Fig. 7-15], click enter key.
- (b) Clicking enter key shows finishing screen of setting as the right screen of [Fig. 8-13].

7.3 XGT Client

7.3.1 XGT client introduction

XGT Client provides a data read/write function sending request frame to server by using XGT dedicated protocol. It sends a frame when the operation condition of each block is ON. By 2 ways communication type of TCP and UDP, XBL-EMTA uses XGT client function.

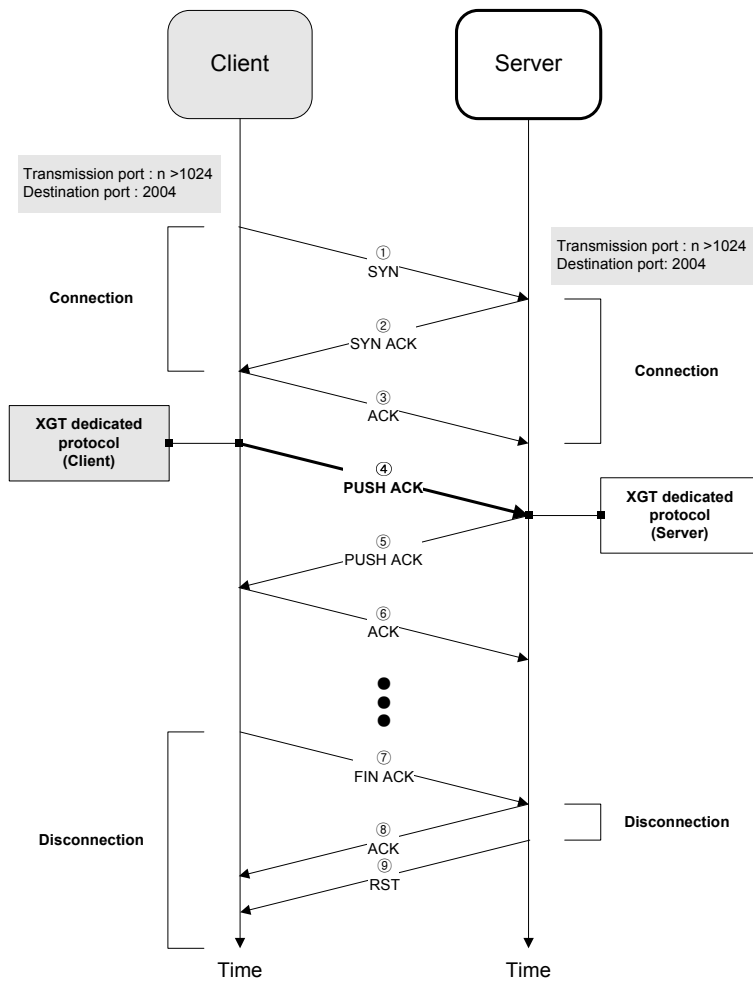

[Fig. 7-16] Setting TCP XGT client channel

7.4 Modbus TCP Client

7.4.1 Modbus TCP Client

Modbus TCP client provides a data read/write function sending request frame to server using function code by Modbus TCP/IP protocol. It sends a frame when the operation condition of each block is ON.

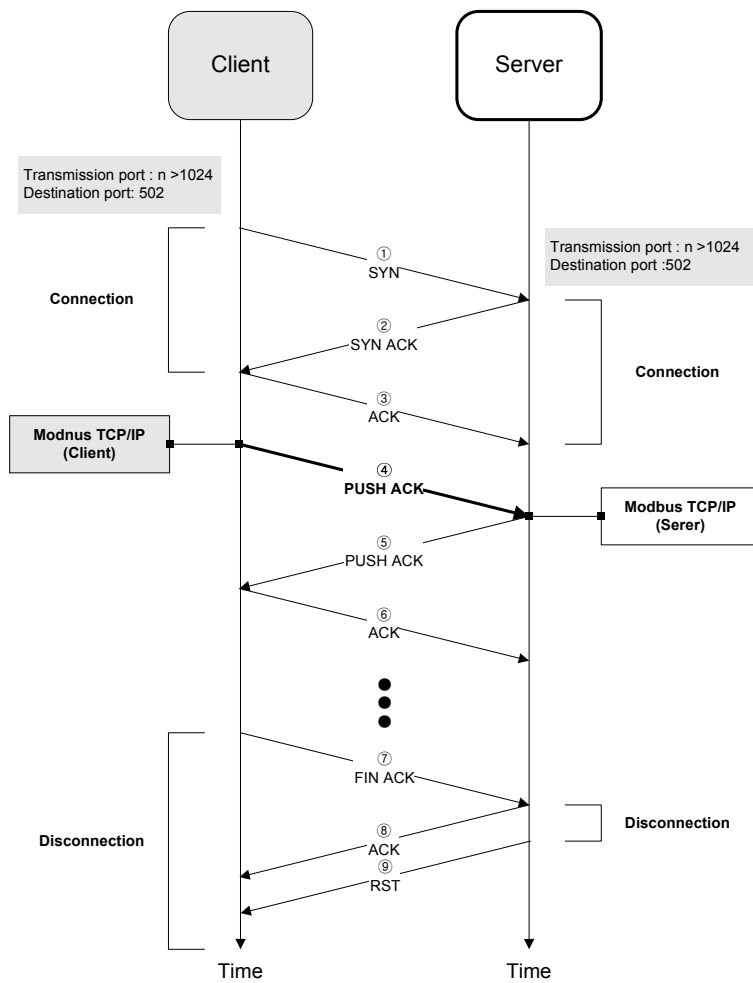

[Fig. 7-17] Setting TCP XGT client channel

7.5 User define frame

7.5.1 TCP user define frame client

(1) Setting user define frame channel

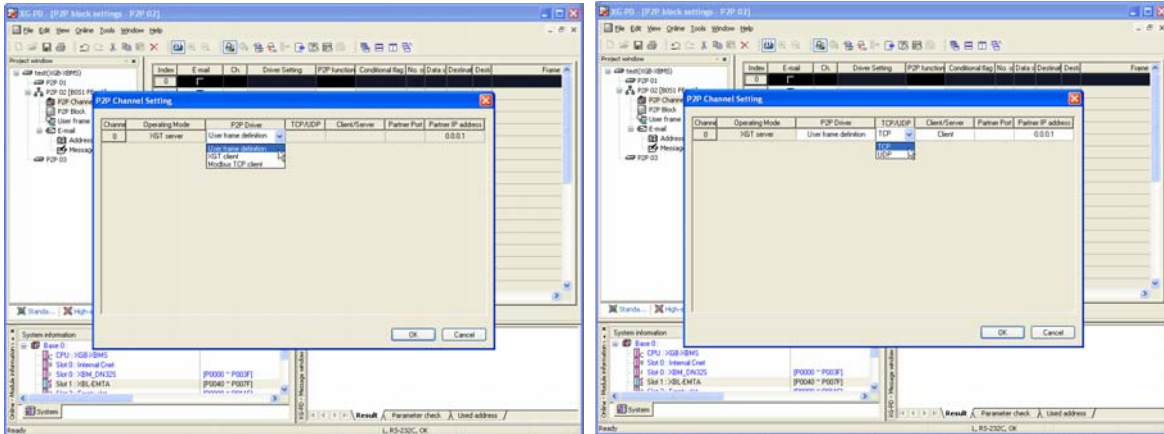

[Fig. 7-18] Setting user define frame channel

- (a) Set the channel driver to user define frame as the left screen of [Fig. 7-18].
- (b) Select TCP/UCP as the right screen of [Fig. 7-18].

(2) Setting user fine frame port no.

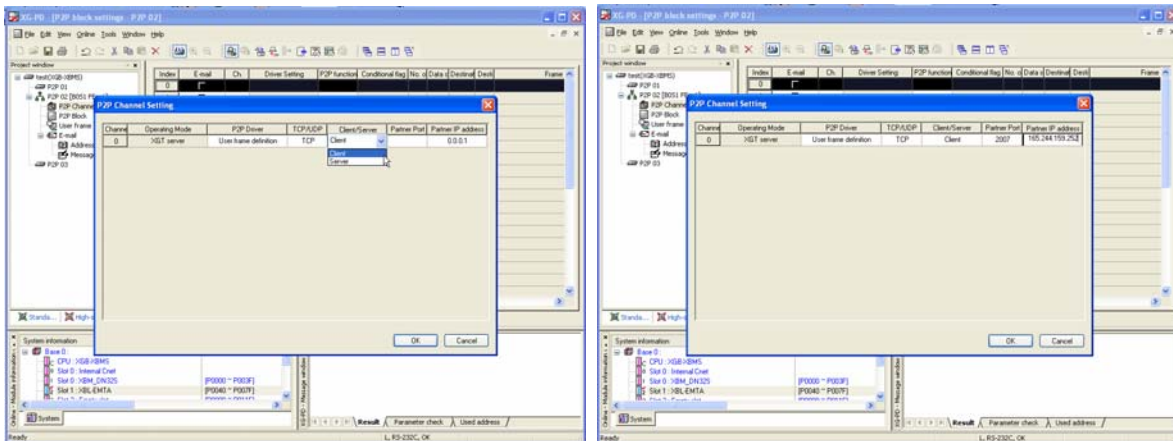

[Fig. 7-19] Setting user fine frame port no

- (a) Set operation mode 'Client/Server' to Client as the left screen of [Fig. 7-19].
- (b) Select TCP/UDP as the right screen of [Fig. 7-19], input the desired port no. and the desired destination IP address.

Chapter 7 P2P Service

(3) Setting user define frame group addition

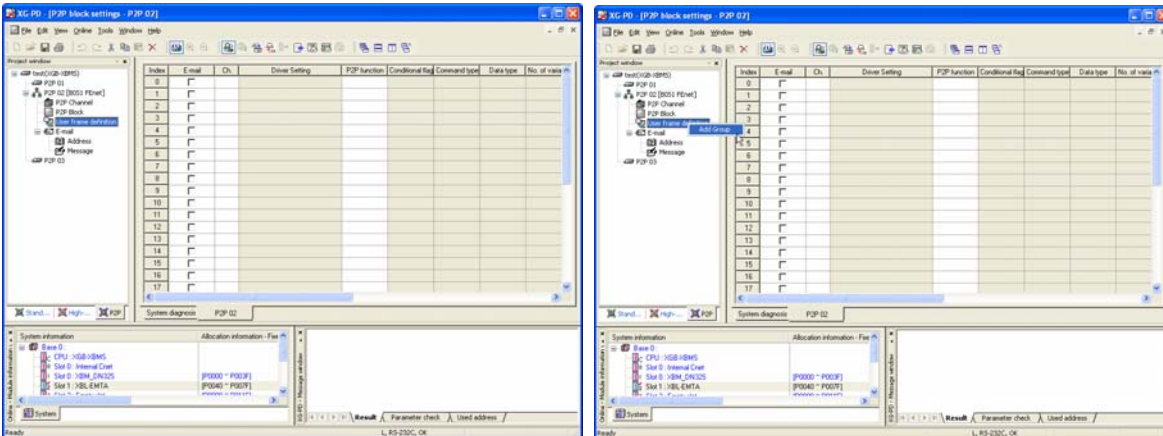

[Fig. 7-20] Setting user define frame group addition

(a) Setting user define frame group addition of [Fig. 7-20]

(b) Select user define frame group addition as the left screen of [Fig. 7-20], click right button of mouse. It shows pop-up menu 'Add Group'. Then, click it again.

(4) Select user define frame group name and frame type

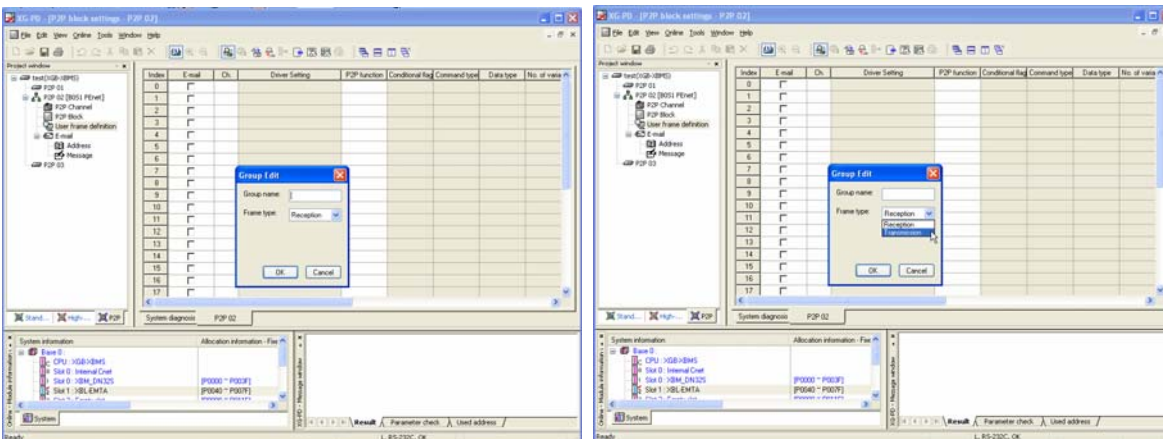

[Fig. 7-21] Select user define frame group name and frame type

(a) Select user define frame group name and frame type of [Fig. 7-21]

(b) Select frame type 'Transmission' on Group Edit as the left screen of [Fig. 7-21].

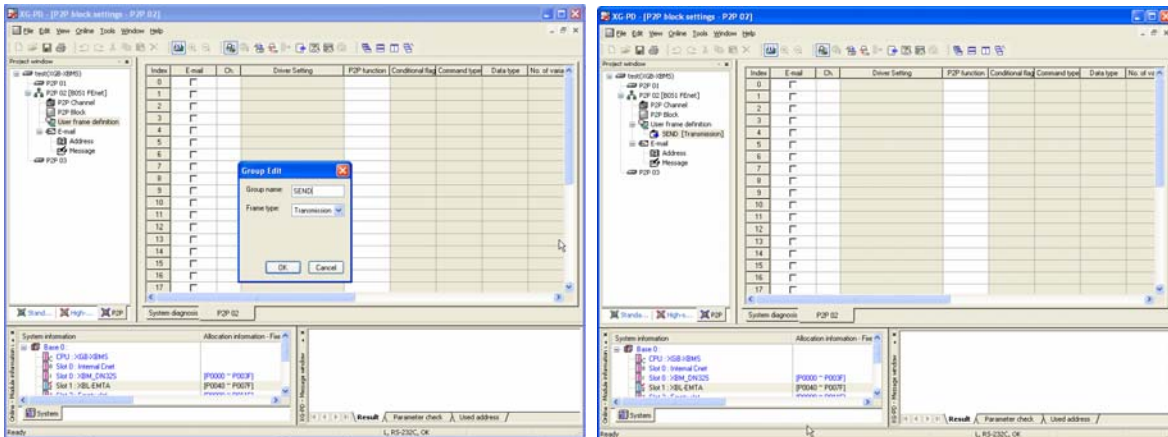

[Fig. 7-22] Finishing user define frame group addition

- (c) Input group name in Group Edit as the left screen of [Fig.7-22]. Group name can be inputted in random.
- (d) Check input information, click enter key. It adds new group on project window as the right screen of [Fig.7-22].

(5) Adding user define frame HEAD

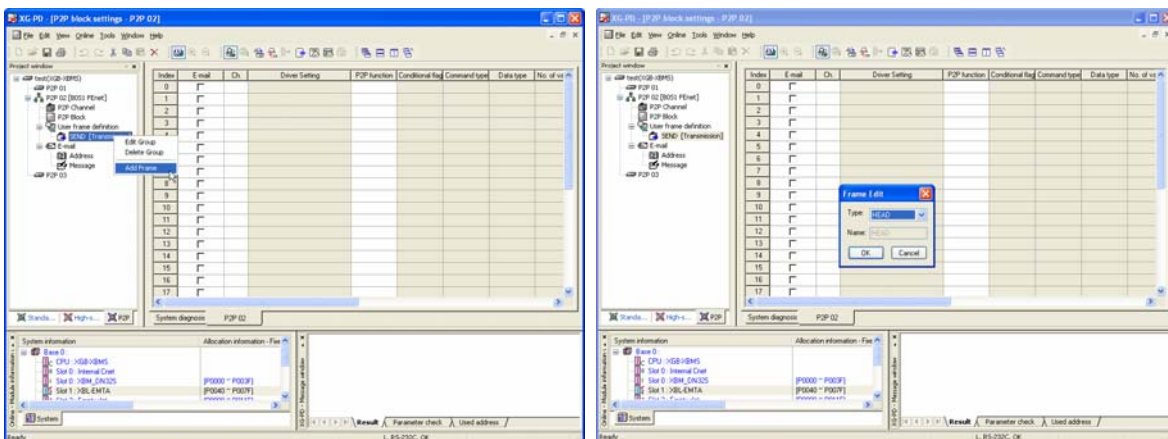

[Fig. 7-23] Adding user define frame HEAD

- (a) Add user define frame HEAD as [Fig. 7-23].
- (b) Click right button of mouse on the added group as the left screen of [Fig. 7-23]. It shows pop-up menu 'Edit Group/Delete Group/Add Frame'.
- (c) Select Add Frame, then click mouse. It shows frame edit window as the right screen of [Fig.7-23].
- (d) Select type-'HEAD', click enter key.
- (e) Clicking enter key, it add HEAD on group of project window as the left screen of [Fig. 7-23].

Chapter 7 P2P Service

(6) Adding user define frame HEAD segment

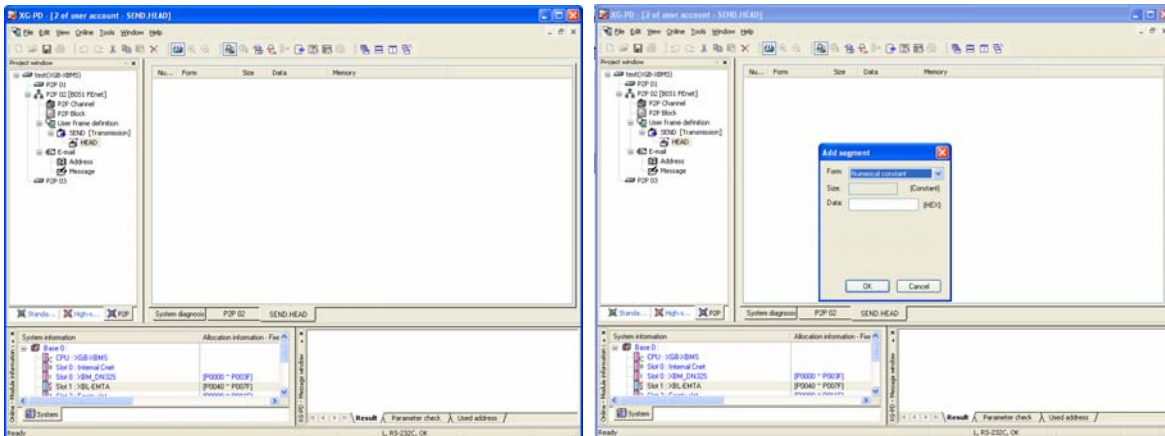

[Fig. 7-24] Adding user define frame HEAD segment

- (a) Double-click SEND.HEAD area as the left screen of [Fig. 7-24]. It shows segment adding window.
- (b) Select type 'Numerical constant' on Add segment.

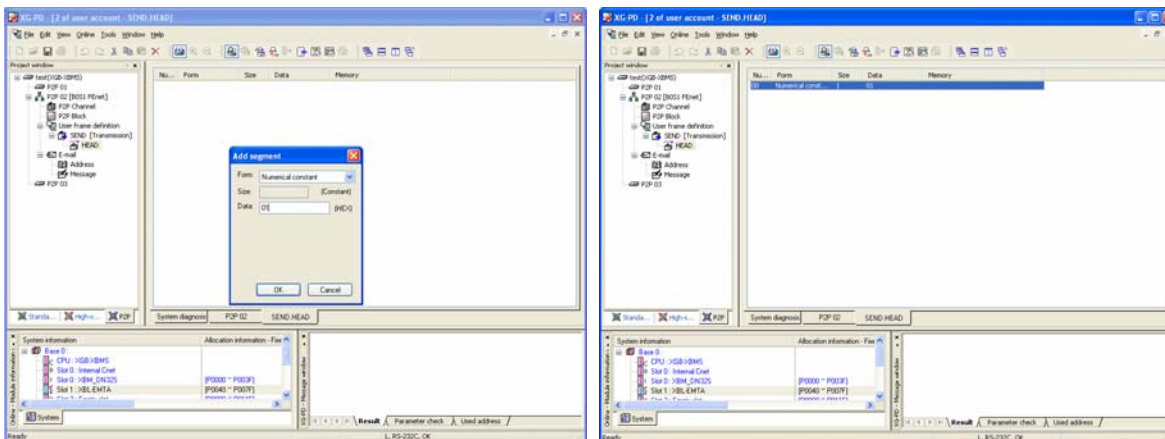

[Fig. 7-25] Finishing user define frame HEAD segment input

- (c) Input data as the left screen of [Fig. 7-25], then click enter key.
- (d) Clicking enter key finishes segment adding as the left screen of [Fig.7-25].

(7) Adding user define frame TAIL

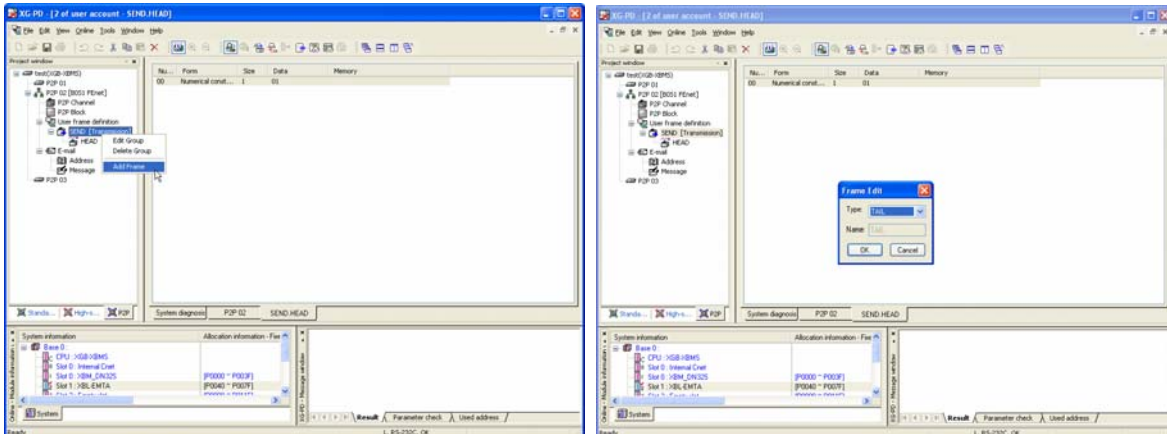

[Fig. 7-26] Adding user define frame TAIL

- (a) Click right button of mouse on the added group as the left screen of [Fig. 7-26]. It shows pop-up menu 'Edit Group/Delete Group/Add Frame'.
- (b) Select Add Frame, click mouse. It shows frame edit window as the right screen of [Fig.7-26].
- (c) Select type 'TAIL', click enter key.
- (d) Clicking enter key adds TAIL on the project window as the left screen of [Fig.7-26].

(8) Adding user define frame TAIL segment

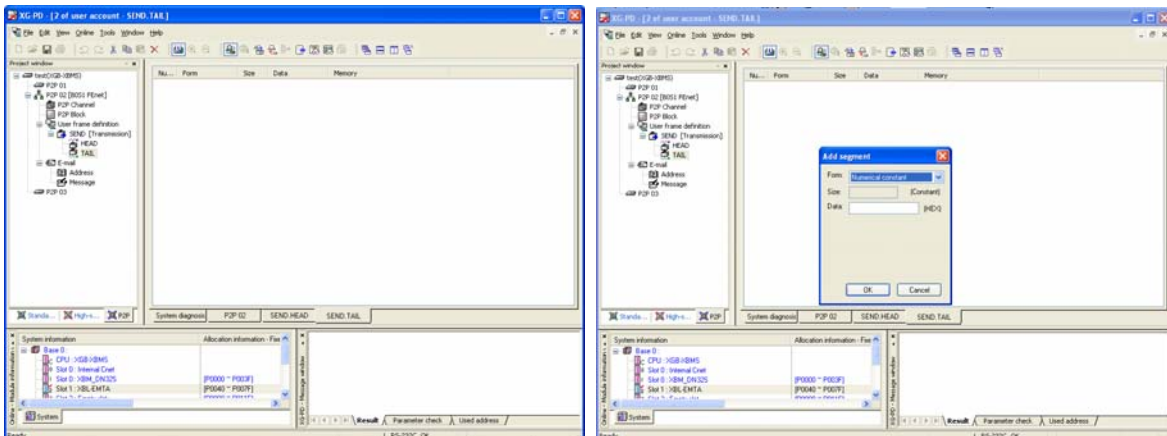

[Fig. 7-27] Adding user define frame TAIL segment

- (a) Double-click SEND.TAIL area as the left screen of [Fig.7-27]. It shows segment adding window.
- (b) Select type 'Numerical constant' on Add segment.

Chapter 7 P2P Service

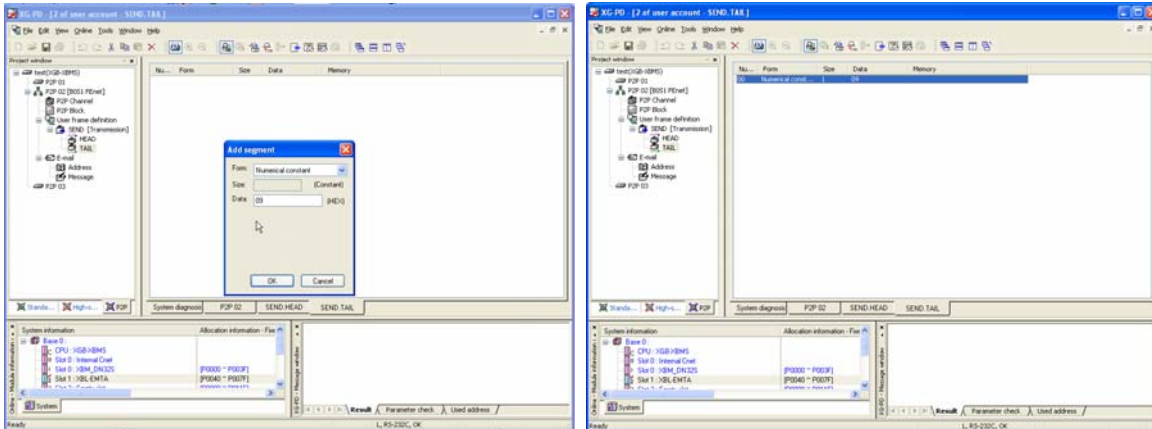

[Fig. 7-28] Finishing user define frame TAIL segment input

- (c) Input data as the left screen of [Fig. 7-28], click enter key.
- (d) Clicking enter key finishes segment adding as the left screen of [Fig.7-28].

(9) Adding user define frame BODY

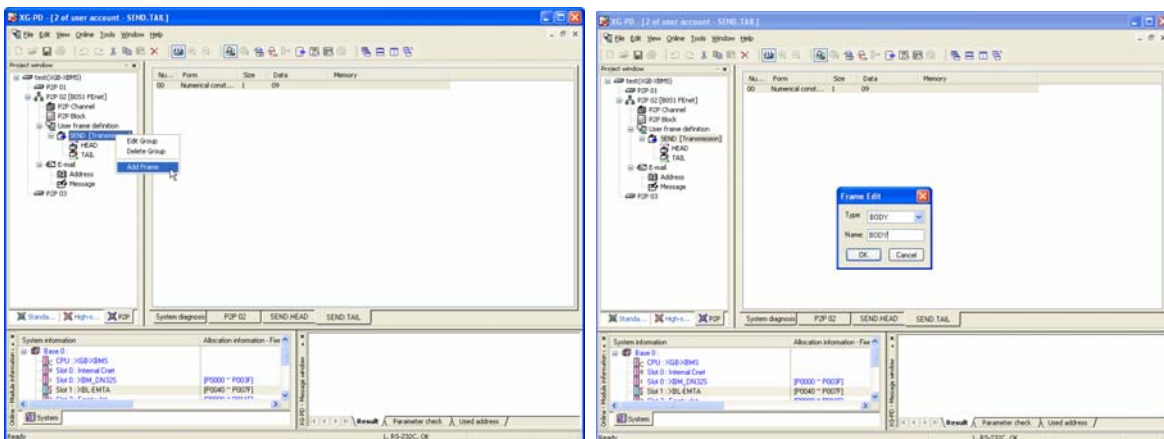

[Fig. 7-29] Adding user define frame BODY

- (a) Click right button of mouse on added group as the left screen of [Fig. 7-29]. It shows pop-up menu 'Edit Group /Delete Group/Add Frame'.
- (b) Select Add Frame, click mouse. It shows Frame Edit window as the right screen of [Fig.7-29].
- (c) Select type 'BODY', click enter key.
- (d) Clicking enter key adds BODY as the left screen of [Fig. 7-29].

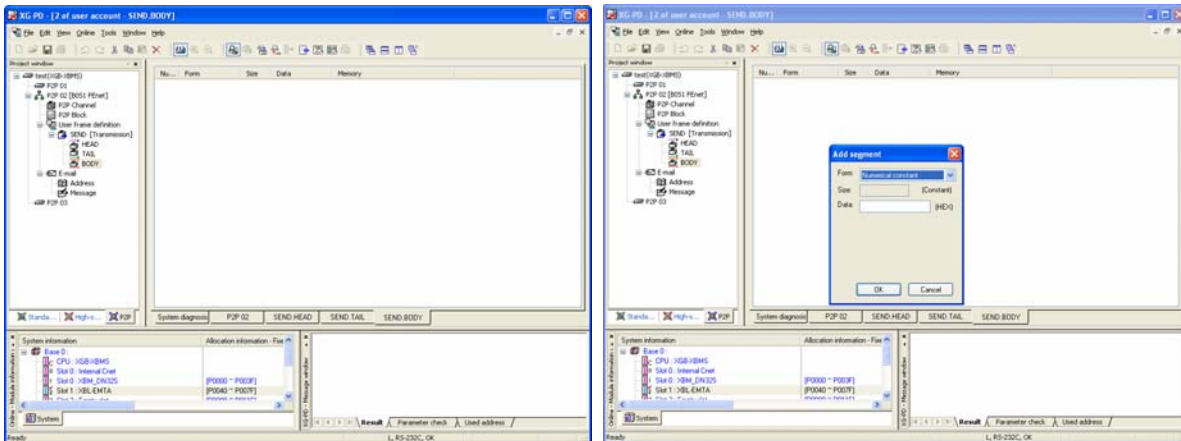

[Fig. 7-30] Adding user define frame BODY

- (e) Double-click SEND.TAIL area as [Fig.7-30]. It shows segment adding window.
- (f) Select type 'Numerical constant' on Add segment.

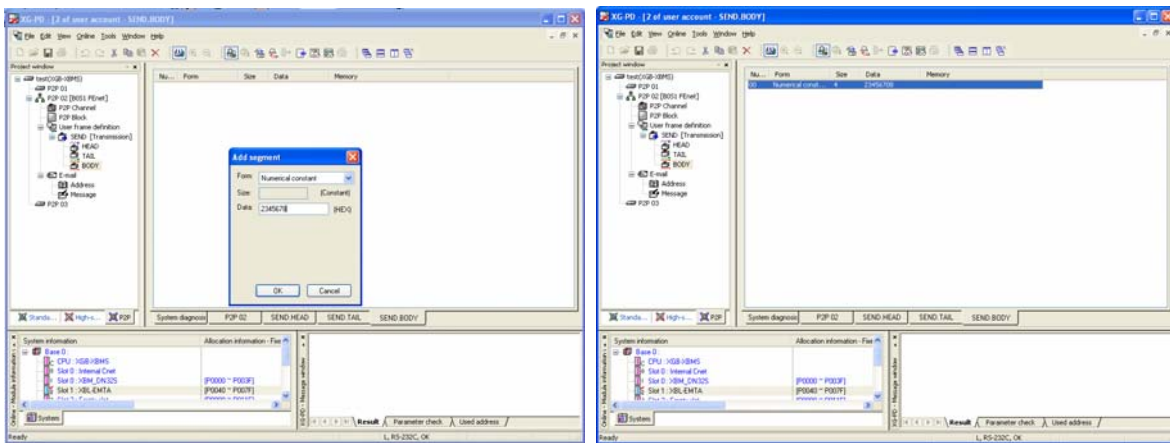

[Fig. 7-31] Finishing setting user define frame segment addition

- (g) Input data as the left screen of [Fig.7-31], click enter key.
- (h) Clicking enter key finishes segment adding as the left screen of [Fig.7-31].

Chapter 7 P2P Service

(10) Setting user define frame block and selecting frame

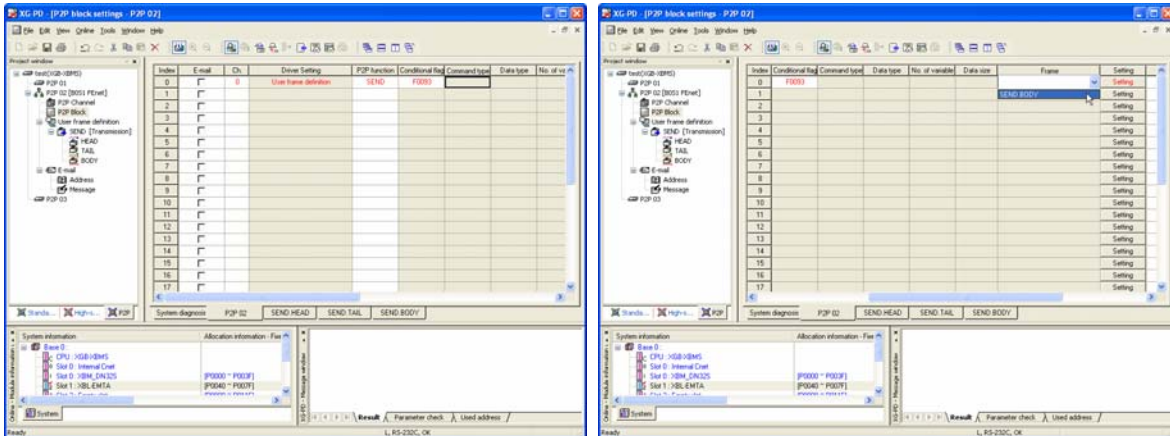

[Fig. 7-32] Setting user define frame block and selecting frame

- (a) Registered group frame can be selected when the setting driver is user define frame.
- (b) Selecting frame finishes setting block as [Fig.7-32].

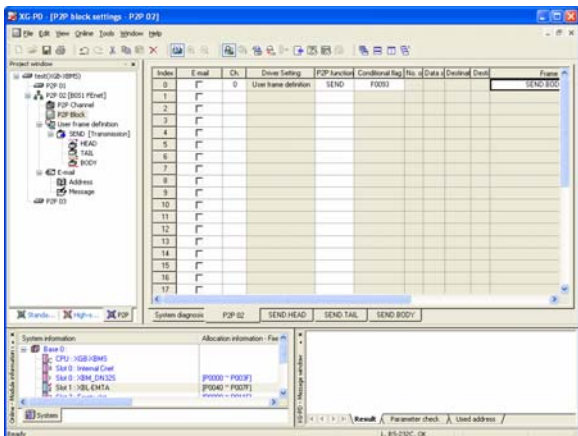

[Fig. 7-33] Finishing user define frame block setting

7.5.2 TCP/UDP user define frame server

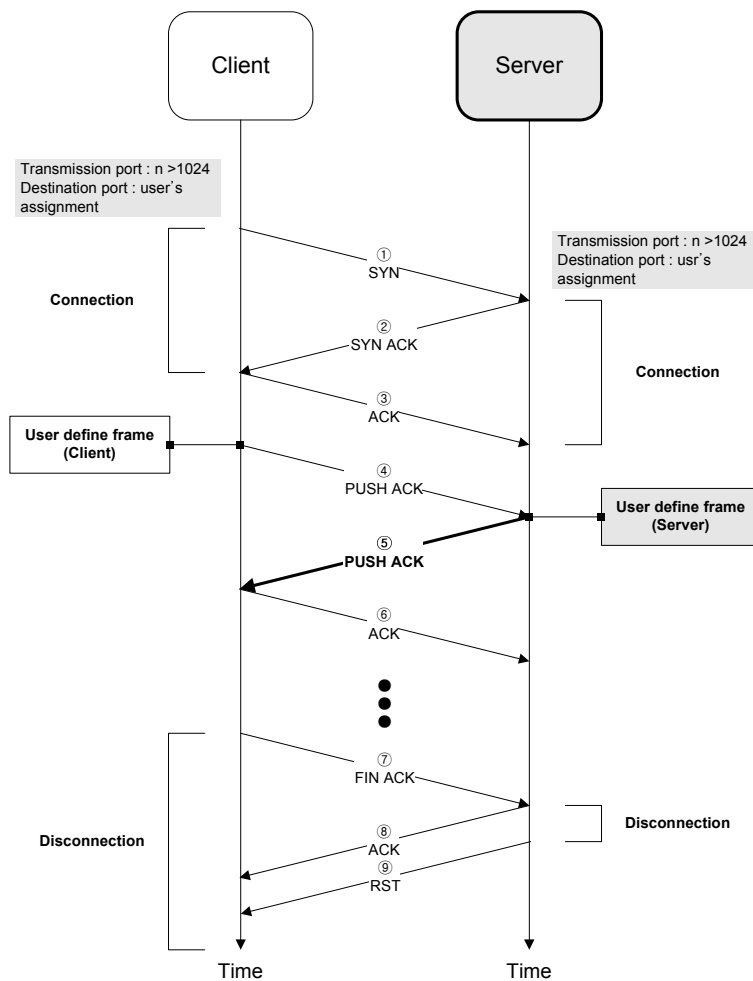

[Fig. 7-34] TCP user define frame server

- (1) TCP user define frame server provides a function receiving the registered frame as the receiving block to the user's assigned port.
- (2) In case of '①SYN ->②SYNACK ->③ACK (Connection)-> the registered frame in reception block 's received from client', TCP user define frame treats the block.
- (3) TCP user define frame does not receive if the port or frame type is different.
- (4) In case of receiving registered frame in reception block to the block, UDP user frame server does receive.

7.5.3 TCP user define frame client

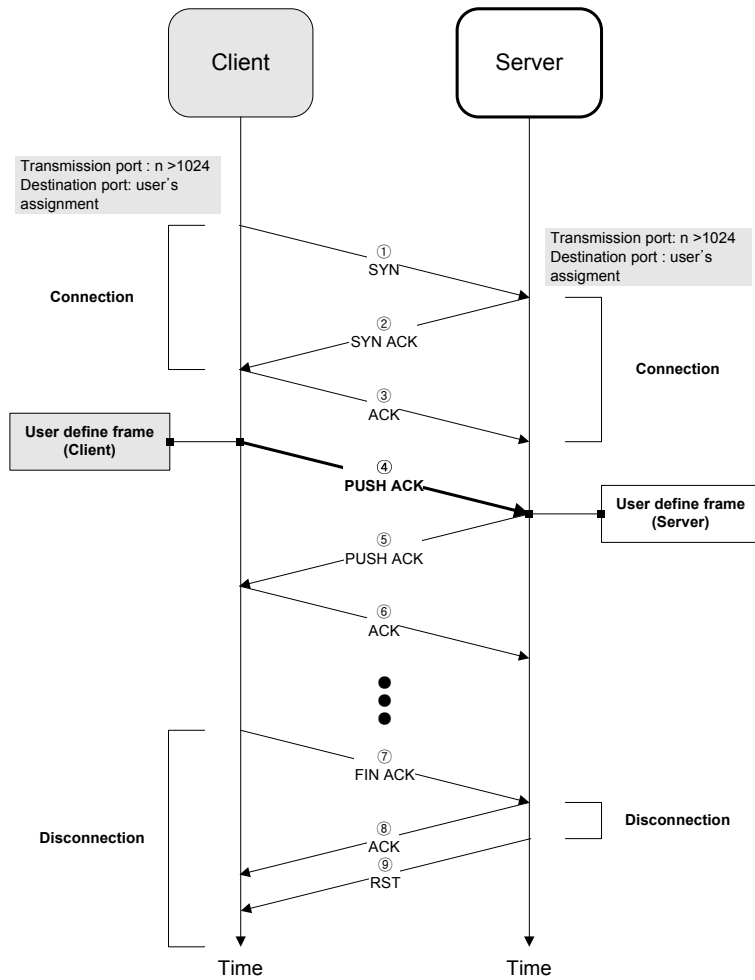

[Fig. 7-35] TCP user define frame client

- (1) TCP user define frame client provides a function sending the registered frame as the sending block to the user's assigned port.
- (2) In case of operation condition -'ON' in block, TCP user define frame client does ① SYN, and send the registered frame in sending block to the port.
- (3) In case of UDP user define frame client does not do ① SYN, it send the frame to the port when the operation condition is 'ON'.

7.6 P2P Diagnosis Function

7.6.1 Service condition diagnosis using XG-PD

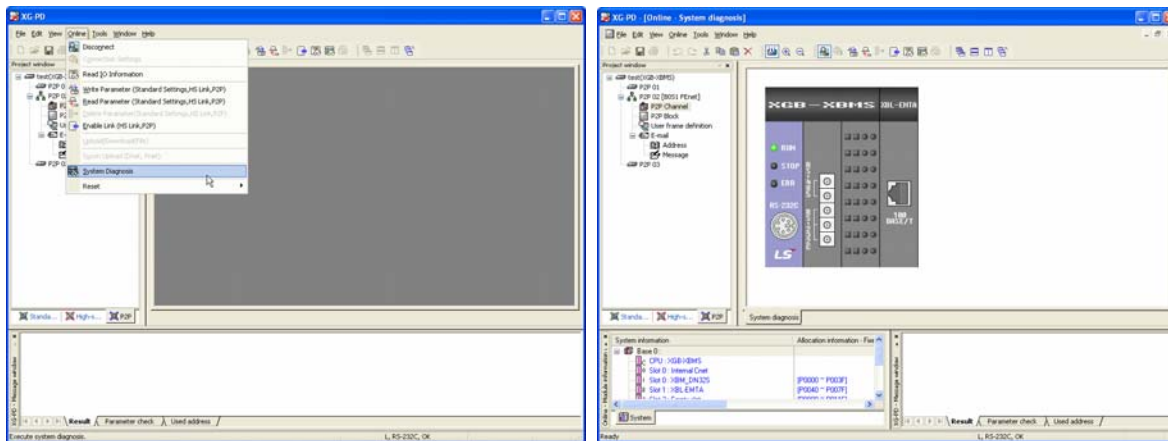

[Fig. 7-36] System diagnosis

- (1) After connecting it through XG-PD, click System Diagnosis as the left screen of [Fig.7-36].
- (2) It shows present system picture as the right screen of [Fig. 7-36]

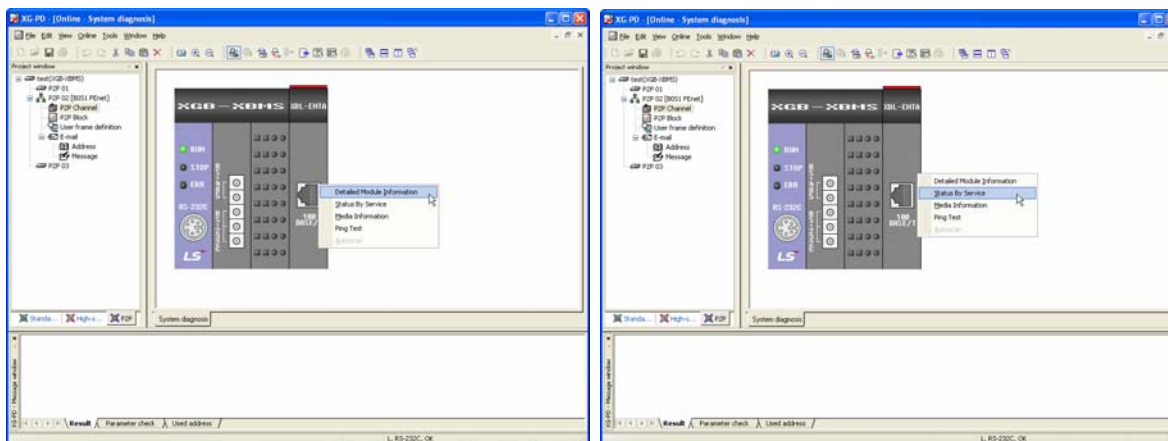

[Fig. 7-37] System diagnosis menu

- (3) Keep positioning on the module as the left screen of [Fig. 7-37] and click the right button of mouse.
- (4) Select Status By Service as the right screen of [Fig. 7-37], click it.

Chapter 7 P2P Service

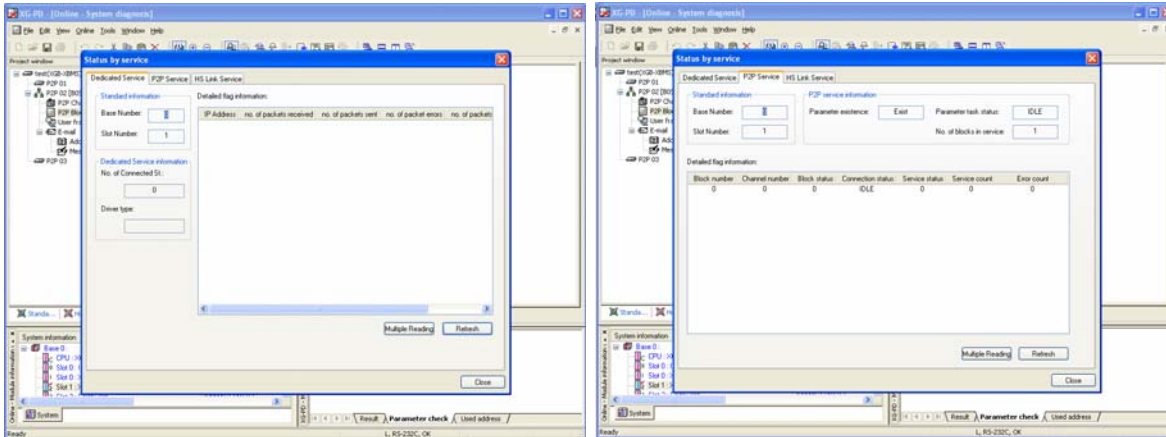

[Fig. 7-38] Status by service

- (5) It shows 'Status by service' window as the left screen of [Fig. 7-38].
- (6) Select P2P service tap, it shows P2P service condition as the right screen of [Fig. 7-38].

Chapter 8 High Speed Link Service

8.1 General

8.1.1 General

HS link service is a communication method between XGB Series and XGT Series PLC communication modules. This service provides that function does send/ receive data periodically by setting parameters. HS link service does send frame to Subnet Broadcast by using UDP protocol. Devices installed in same Subnet receives this Broadcast frame at the same time, it provides data treatment when one frame is registered in reception list.

Followings are HS link functions.

- (1) Setting HS link block
 - (a) Max. 128 blocks can be set in case of lots send/reception area.
 - (b) Max. 200 words can be set per 1 block.
- (2) Setting Period type
 - (a) User can set period of type by parameter
 - (b) User can set period of sending/receiving, 20ms~10sec.
- (3) Setting area of sending/receiving
 - (a) User can set area of sending/receiving by data block.
 - (b) Max. 32 blocks of each sending/receiving are available.
- (4) HS link information
 - (a) HS link operation condition can be check through Flag.
 - (b) Comfortable system diagnosis using XG-PD.

8.2 Setting HS link service

8.2.1 Basic parameter

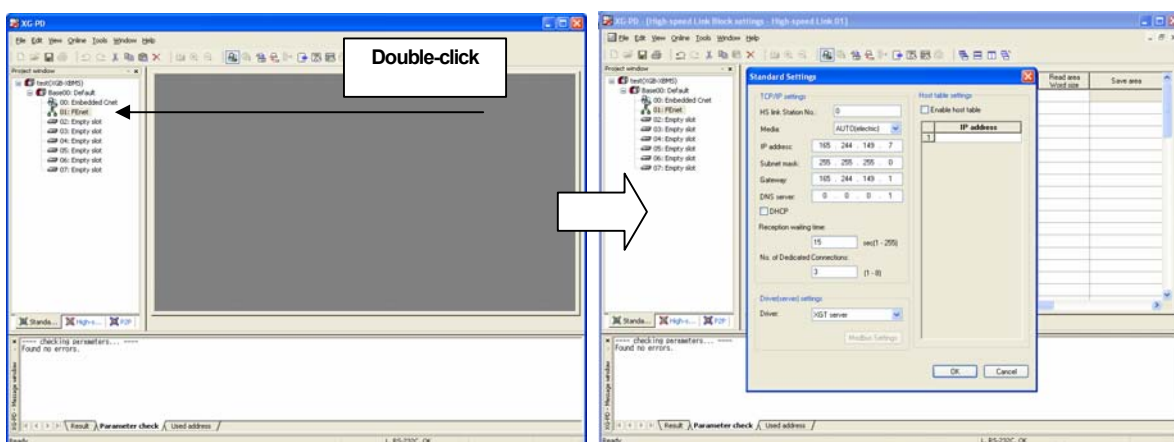

[Fig. 8-1] Setting basic parameter station no.

8.2.2 HS link parameter

(1) Setting communication module

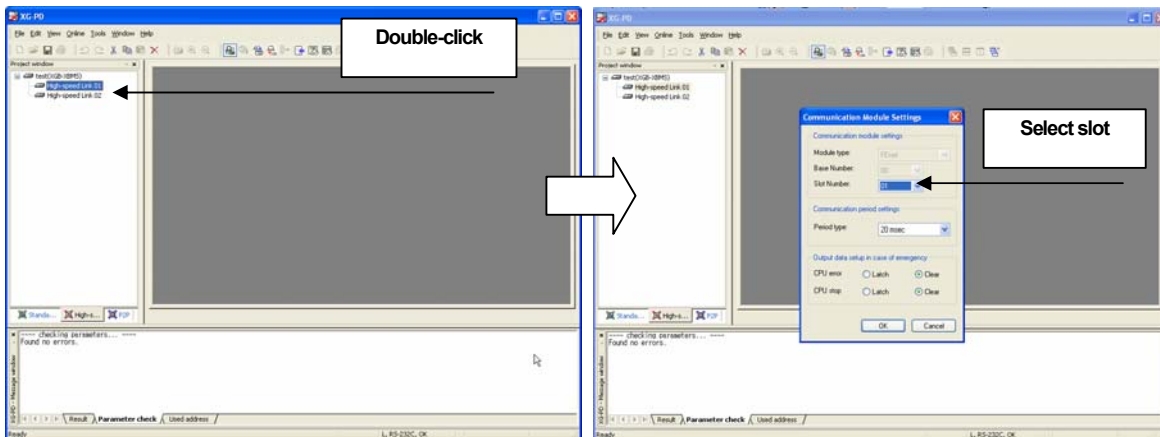

[Fig. 8-2] Setting communication module in HS link parameter

- (a) Select HS link 01 or HS link 02 on project window as the left screen of [Fig. 8-2], double-click it.
- (b) Double-clicking shows communication module information setting window as the right screen of [Fig.8-2].

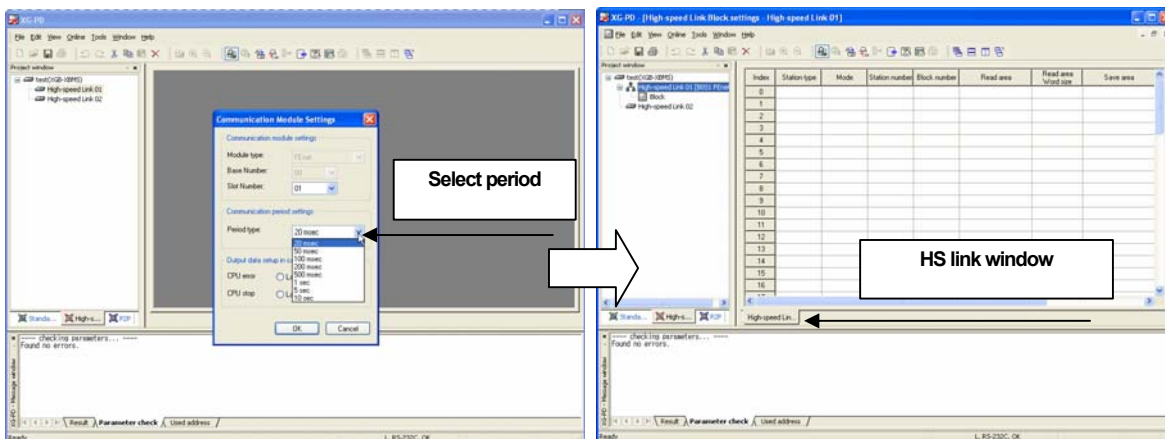

[Fig. 8-3] Finishing HS link communication module setting

- (c) Select the desired period of communication as the left screen of [Fig. 8-3].
- (d) Clicking enter key shows block setting screen as the right screen of [Fig. 8-3].

(2) Setting HS link sending block

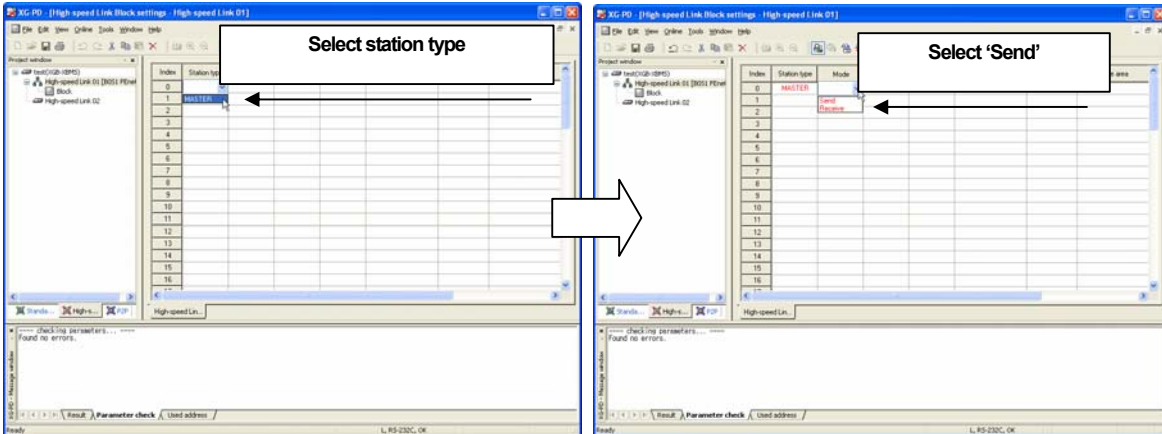

[Fig. 8-4] Setting HS link Sending Block station type and mode

- (a) Set station type 'MASTER' as the left screen of [Fig. 8-4].
- (b) Select mode 'Send' as the right screen of [Fig. 8-3].

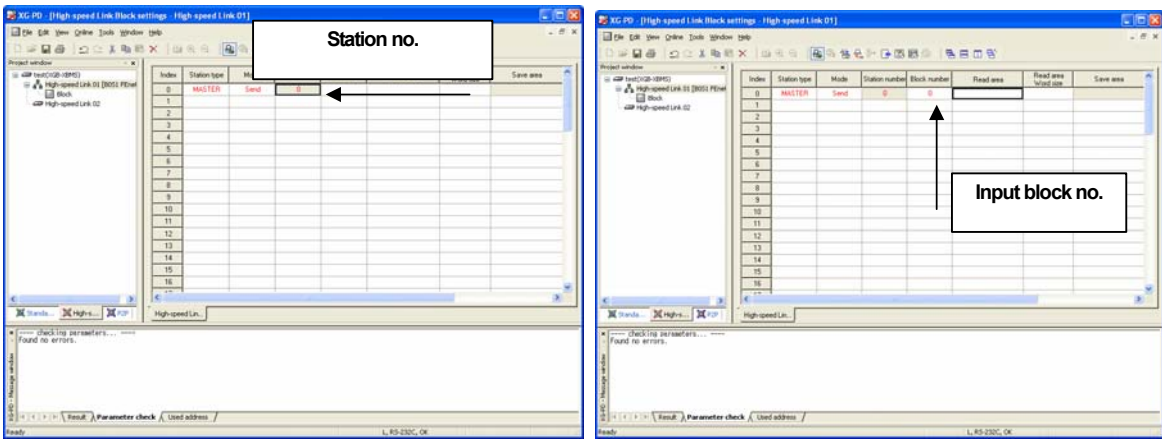

[Fig. 8-5] Setting HS link sending block station no. and block no.

- (c) When an user selects sending as the left screen of [Fig. 8-5], it sets setting station no. in basic parameter.
- (d) Input block no. as the right screen of [Fig. 8-5].

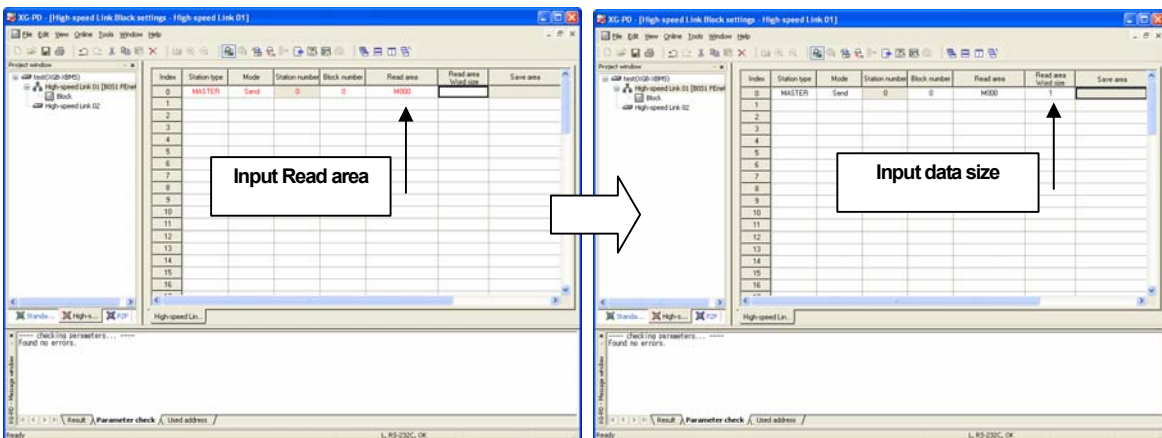

[Fig. 8-6] Finishing HS link sending block data size setting

Chapter 8 High Speed Link Service

- (e) Input READ area as the left screen of [Fig. 8-6]. READ area is each area of XGB CPU module.
- (f) Inputting word size of READ area as the right screen of [Fig. 8-6] finishes setting sending block .

(3) Setting HS link receiving block

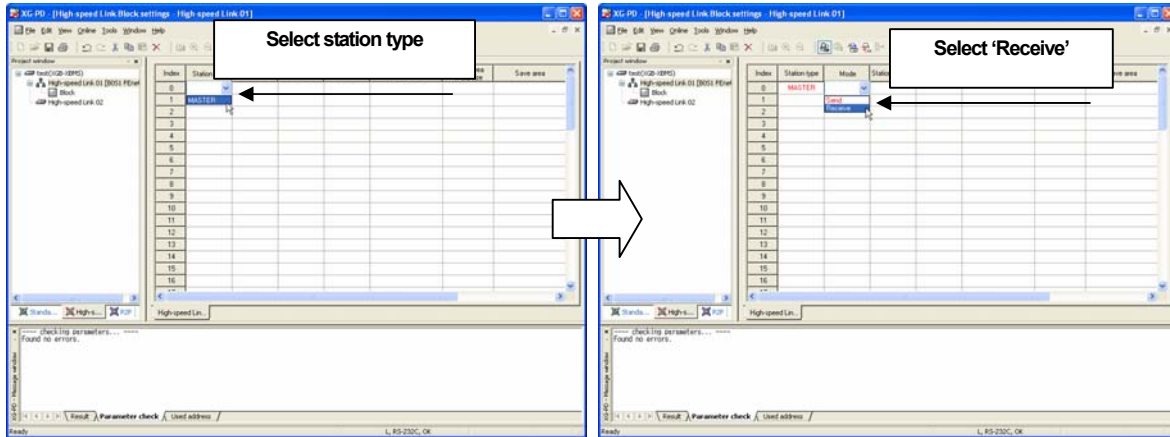

[Fig. 8-7] Setting HS link receiving block station type and mode

- (a) Set station type 'MASTER' as the left screen of [Fig. 8-7]
- (b) Select mode 'Receive' as the right screen of [Fig. 8-7]

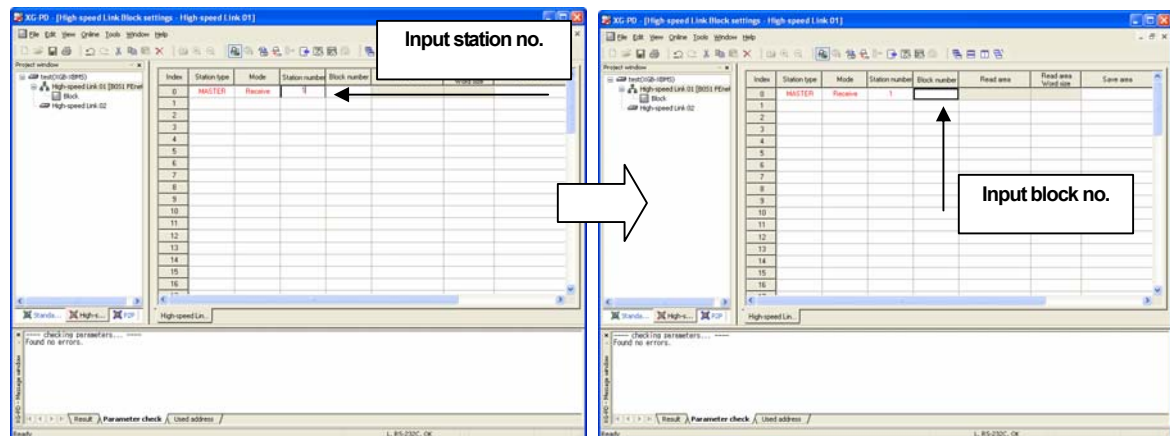

[Fig. 8-8] Setting HS link receiving block station no. and mode

- (c) Input station no. as the left of [Fig. 8-8]. This station no. is the number of destination device sending the block.
- (d) Input block no. as the right screen of [Fig. 8-8]. It receives when the received frame is same as the block no.

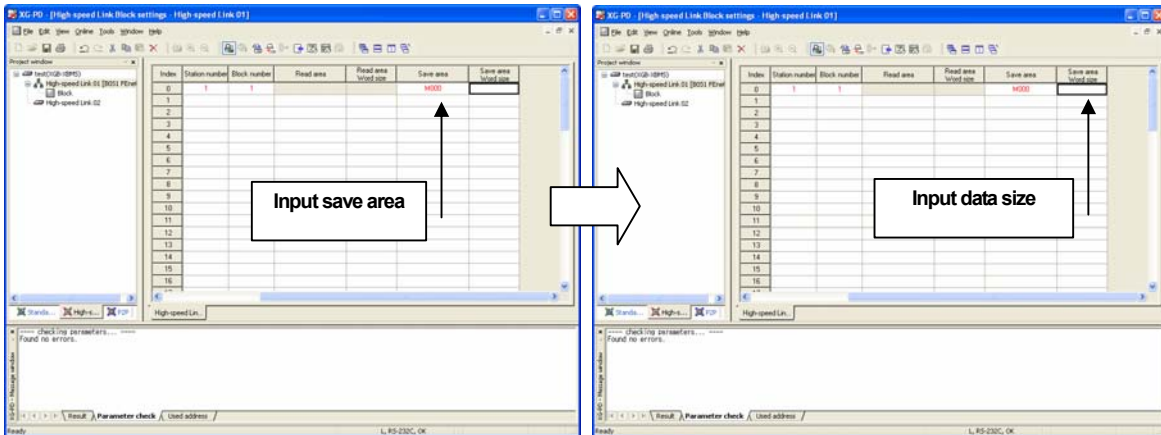

[Fig. 8-9] Setting HS link receiving block station no. and mode

- (e) Input save area as the left screen of [Fig 8-9]. Save area is the data saving area when each area of XGB CPU module receives the frame of block no.
- (f) Inputting word size of Read area as the right screen of [Fig. 8-9] finishes setting receiving block.

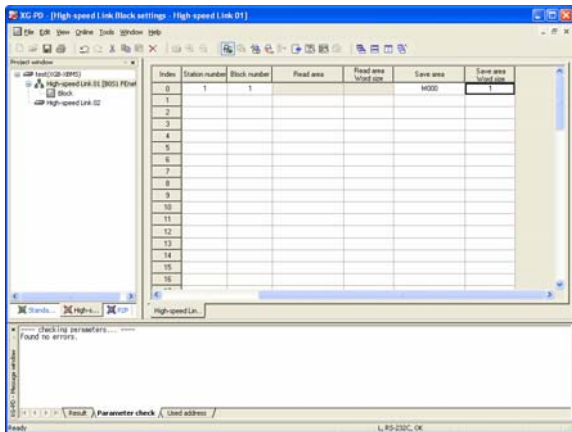

[Fig. 8-10] Finishing HS link receiving block data size setting

Chapter 8 High Speed Link Service

(4) HS link enable

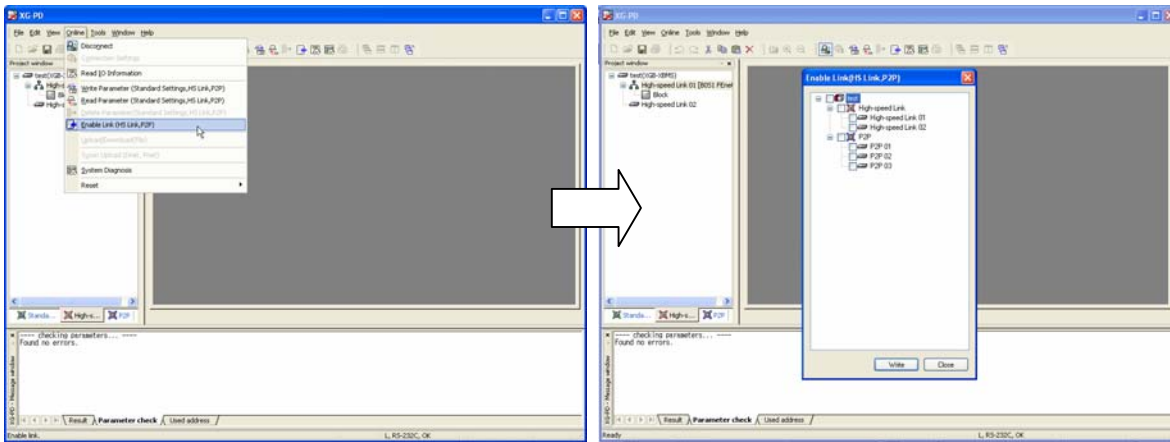

[Fig. 8-11] HS link enable

- (a) Connecting it through XG-PD, click link enable on On-line menu.
- (b) Select HS link 01 or HS link 02.

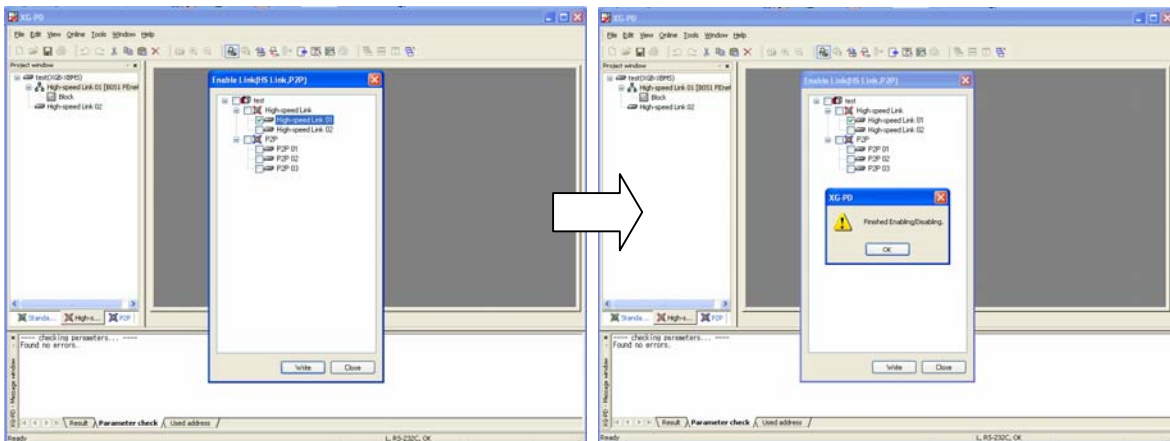

[Fig. 8-12] Finishing HS link enable

- (c) Click check box, then click write button.
- (d) When the message's outputted, clicking enter key starts HS link communication.

8.3 HS Link Flag

HS link service exchanges between over 2 stations of communication modules. To verify the reliability of read data from destination station through HS link, HS link service provides HS link information to user.

Communication module provides HS link information synthesizing receiving data by the time every some general interval And it verifies if the HS link operates in good condition followed by the user's assigned parameter.

HS link service is composed of followings.

- (1) Run- Link (_HSxRLINK): It shows communication network overall information,
- (2) Overall information of Link-Trouble (_HSxLTRBL)
- (3) _HSxSTATE, _HSxTRX, _HSxMOD, _HSxERR: Individual information. It shows each communication status by 64 registered item in parameter

User can use upper information in Key word type for programming. And by using HS information monitor function, user can monitor the status of HS link. Operating many PLCs by using HS link, user should do the operation after verifying the reliability of Send/Receive data with understanding Run-Link, Link-Trouble, etc. [Table 8-13] shows HS link information function and definition.

8.3.1 HS link flag classification

Classification	Run-Link	Link-Trouble	Send/Receive status	Operation Mode	Error	HS link status
Information type	Overall	Overall	Individual	Individual	Individual	Individual
Keyword name (x=HS Link No.)	_HSxRLINK	_HSxLTRBL	_HSxTRX[n] (n=0..64)	_HSxMOD[n] (n=0..64)	_HSxERR[n] (n=0..64)	_HSxSTATE[n] (n=0..64)
Data type	Bit	Bit	Bit-Array	Bit-Array	Bit-Array	Bit-Array
Monitor availability	Yes	Yes	Yes	Yes	Yes	Yes
Program usability	Yes	Yes	Yes	Yes	Yes	Yes

[Fig. 8-13] HS link flag

8.3.2 HS link flag introduction

(1) Run-Link Flag

Overall information, it shows if HS link operates in good condition by the user's assigned parameter.

It keeps 'On' by the time of permitting 'Off' when it is 'On' once, and it is 'On' under following conditions.

- (a) When the permitting link is 'On'.
- (b) When all parameter registration item setting is normal.
- (c) When every data which is included in parameter registration item Send/Receive as the setting period.
- (d) Status of every setting destination station in parameter is RUN and at the moment there's no error.

(2) Trouble-Link Flag

(a) It shows if HS link operates in good condition by the user's assigned parameter.

(b) In the status of 'On' of Run-Link, if Run-Link is out of 'On' condition, it becomes 'On' and it does 'Off' when it recovers.

Chapter 8 High Speed Link Service

- (3) Synthesized status indication Flag of Block
- It's an individual information showing operation status by HS link parameter registration item.
 - It indicates Max. 128 of HS link status by registration item and Max. registration numbers.
 - It shows the synthesized information of registration item by synthesizing individual information.
 - When the status of Send/Receive of the list is normal and operation mode is Run, no-error, it becomes 'On' and when it's out of upper condition, it does 'Off'.
- (4) Run Operation Mode Flag of Block Station
- It's an individual information showing operation status by HS link parameter registration item.
 - It indicates Max. 128 of operation mode information by registration item and Max. registration numbers.
 - When the setting station in registration item is Run mode, the Bit becomes 'On'. When it's 'Stop/Pause/Debug' mode, it does 'Off'.
- (5) Normal communication indication Flag between block station
- It's an individual information showing operation status by HS link parameter registration item.
 - It indicates Max. 128 of Send/Receive information by registration item.
 - When Send/Receive operates in good condition as the setting period, the Bit becomes 'On', if not it does 'Off'.
- (6) Operation Error mode Flag of block station
- It's an individual information showing operation status by HS link parameter registration item.
 - It indicates Max. 128 of error information by registration item and Max. registration numbers.
 - Error defines that PLC does not execute user program normally. It means the operation of destination station is normal when it's 'Off'. It does the operation of destination station is abnormal.

8.3.3 HS link flag memory address

HS link flag is assigned in memory area (LAREA) of CPU.

Classification	Variables	Type	Device	Description
Run-Link	_HS1_RLINK	BIT	L00000	HS link No.1 all station normal operation
	_HS2_RLINK	BIT	L00260	HS link No.2 all station normal operation
Trouble-Link	_HS1_LTRBL	BIT	L00001	After _HS1RLINK ON, abnormal status
	_HS2_LTRBL	BIT	L00261	After _HS2RLINK ON, abnormal status
Status	_HS1_STATE000	BIT	L00020	Synthesized status of HS link block No.1 No.000
	~	~	~	~
	_HS1_STATE063	BIT	L0005F	Synthesized status of HS link block No.1 No.063
	~	~	~	~
Mode	_HS2_STATE000	BIT	L00280	Synthesized status of HS link block No.2 No.000
	~	~	~	~
	_HS2_STATE063	BIT	L0031F	Synthesized status of HS link block No.2 No.063
	~	~	~	~
Mode	_HS1_MOD000	BIT	L00060	Run Operation mode of HS link block station No.1 No.000
	~	~	~	~
	_HS1_MOD063	BIT	L0009F	Run Operation mode of HS link block station No.1 No.063
	~	~	~	~
Mode	_HS2_MOD000	BIT	L00320	Run Operation mode of HS link block station No.2 No.000~
	~	~	~	~
	_HS2_MOD063	BIT	L0035F	Run Operation mode of HS link block station No.2 No.000
	~	~	~	~
Send/Receive	_HS1_TRX000	BIT	L00100	Normal communication with HS link block No.1 No.000
	~	~	~	~
	_HS1_TRX063	BIT	L0013F	Normal communication with HS link block No.1 No.063

Classification	Variables	Type	Device	Description
	_HS2_TRX000 ~ _HS2_TRX063	BIT ~ BIT	L00360 ~ L0039F	Normal communication with HS link block No.2 No.000 ~ Normal communication with HS link block No.2 No.063
Error	_HS1_ERR000 ~ _HS1_ERR063	BIT ~ BIT	L00140 ~ L0017F	Operation error mode of HS link block No.1 No.000 ~ Operation error mode of HS link block No.1 No.063
	_HS2_ERR000 ~ _HS2_ERR063	BIT ~ BIT	L00400 ~ L0043F	Operation error mode of HS link block No.2 No.000 ~ Operation error mode of HS link block No.2 No.063

[Fig. 8-14] HS link flag address

Chapter 9 Remote Communication Control

9.1 General

Remote communication control is a function for programming, download of user program, program debugging, monitoring, etc in network system where PLCs are connected with each other Enet by remote control without moving the physical connection status of XD-PD.

It is convenient for easy access to each device from a place without repositioning when network-connected devices are separated far. Communication service function creates the following logical path to attain its purpose.

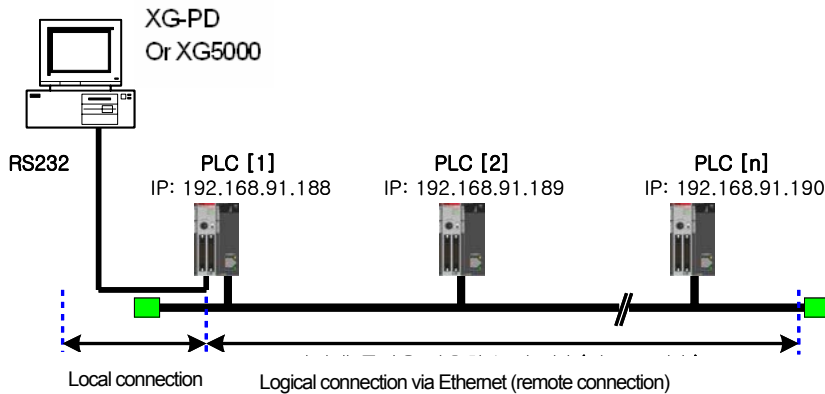

[Fig. 9-1]

A network is supposed where RS-232C cable is connected to PLC #1, and PLC #1, PLC #2, PLC #N are connected with each other via Enet.

In order to access the contents of PLC #1 in [Fig.9-1], do local connection on XG-PD online menu, then access the contents of PLC #1. After finishing access, to access the contents of PLC #N, disconnect the access with PLC #1.

Then, select PLC # N (Station No: N, FEnet slot of PLC #1: 2), accessing it connects logical connection between RS-232C and Enet.

This status as processed identically to connection with RS-232C as moved to PLC #N station is available to execute all functions of program, download, debugging and monitoring as in PLC #1.

Furthermore, when a PC with operating XG-PD is installed with Enet module is installed, and it's connected to same network with the PLC, it can directly do remote 1 connection with PLC without local connection through RS-232C,

With this remote communication service, easy access to PLC position in the distance is available without moving thereto, which is useful for maintenance of PLC system.

9.2 XG-PD Setting and Connection

All PLCs connected with XGT network are available to connect each PLCs by XG-PD communication service. XG-PD remote connection is composed of remote 1 connection (Hereafter, referred to as **remote 1**) and remote 2 Connection (Hereafter, referred to as **remote 2**)

Following shows remote1 and remote 2

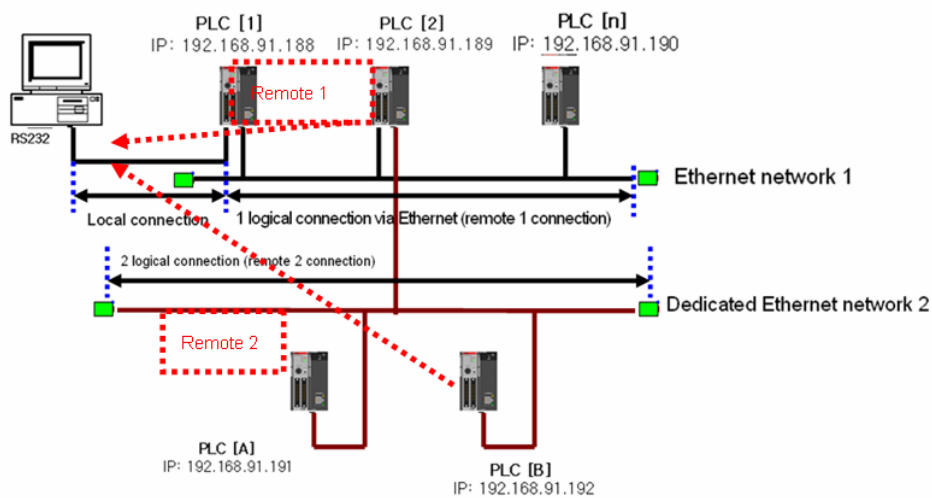

[Fig. 9-2] XG-PD remote connection

[Fig. 9-2] shows examples of remote1 (PLC B) and remote 2 (PLC E) in a system which composed of 2 networks.

9.2.1 Remote 1 (RS-232C Cable)

For remote 1, XG-PD shall be in off-line status. In this status, select 'Option' from the project menu. It shows option dialogue box. Then, select 'Option' tap.

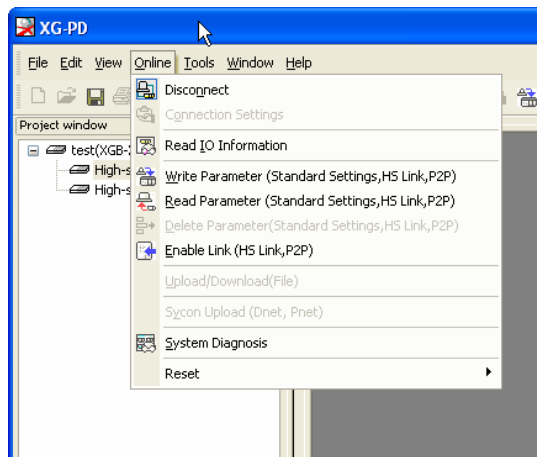

[Fig. 9-3] XG-PD remote connection option selecting

- (1) Connection type
 - (a) Select local connection type. [Fig. 9-3] shows a local connection by using RS-232C
 - (b) Select the communication port from user PC port.
 - (c) Following section explains the case of Enet user.
 - (d) Refer to the user manual of each communication module.
- (2) Connection stage
 - (a) It decides local or remote 1 or remote 2 for connecting PLC.
 - (b) Select remote 1.

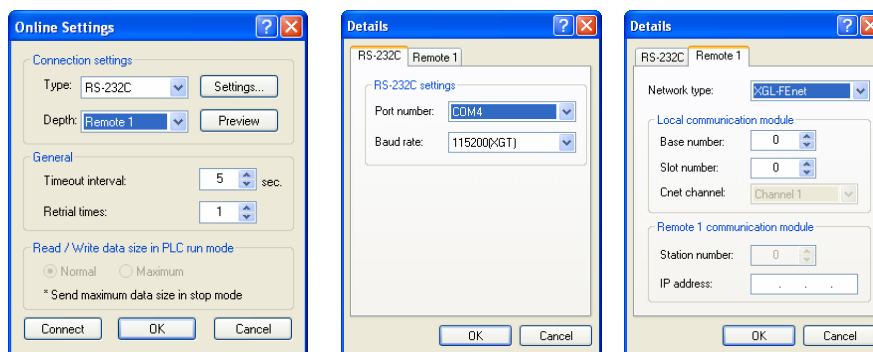

[Fig. 9-4] XG-PD remote 1

- (3) Connecting
 - (a) Select Rnet, Fdnet, Cnet, FEnet, FDEnet by the remote 1 network type.
 - (b) [Fig. 9-4] shows remote 1 through FEnet.
 - (c) Select XGL-Enet.

- (4) Base No.
 - (a) Assign Base No. that is installed with FEnet I/F module for remote connection.

- (5) IP address
 - (a) FEnet I/F module IP that installed in destination station PLC for remote 1 in network 1
 - (b) Assign address. [Fig.9-4] shows the connection to FEnet I/F module of IP address 168.192.12.13.

- (6) Slot
 - (a) It shows the position of communication module which is connected to network 1 from local PLC by RS-232C.
 - (b) In [Fig. 9-4], FEnet I/F module is installed in PLC A. Select the slot no.0.
 - (c) Select enter on (b), then select connection online menu.
 - (d) The status of finishing remote 1 is same as the logical connection status with local connection by moving RS-232C cable.
 - (e) User can use all function of online menu. (But user can't do when the type of PLC and present open project CPU are not matched)

Remark

- 1) Caution for remote connection
Do remote connection after programming which is for the destination CPU type. If the CPU type is not a right match, it only do limited functions, it can not do program upload, download and monitoring.

9.2.2 Remote 2 (RS-232C Cable)

Remote 2 sets connection stage/remote2 from project/option/connection option.

[Fig.9-5] shows remote 2, it's an example of connection to Fnet I/F module of PLC E through FEnet I/F module of PLC B.

To do remote 2, at the connection stage of project/option/connection option, select remote 2, then it shows the following box.

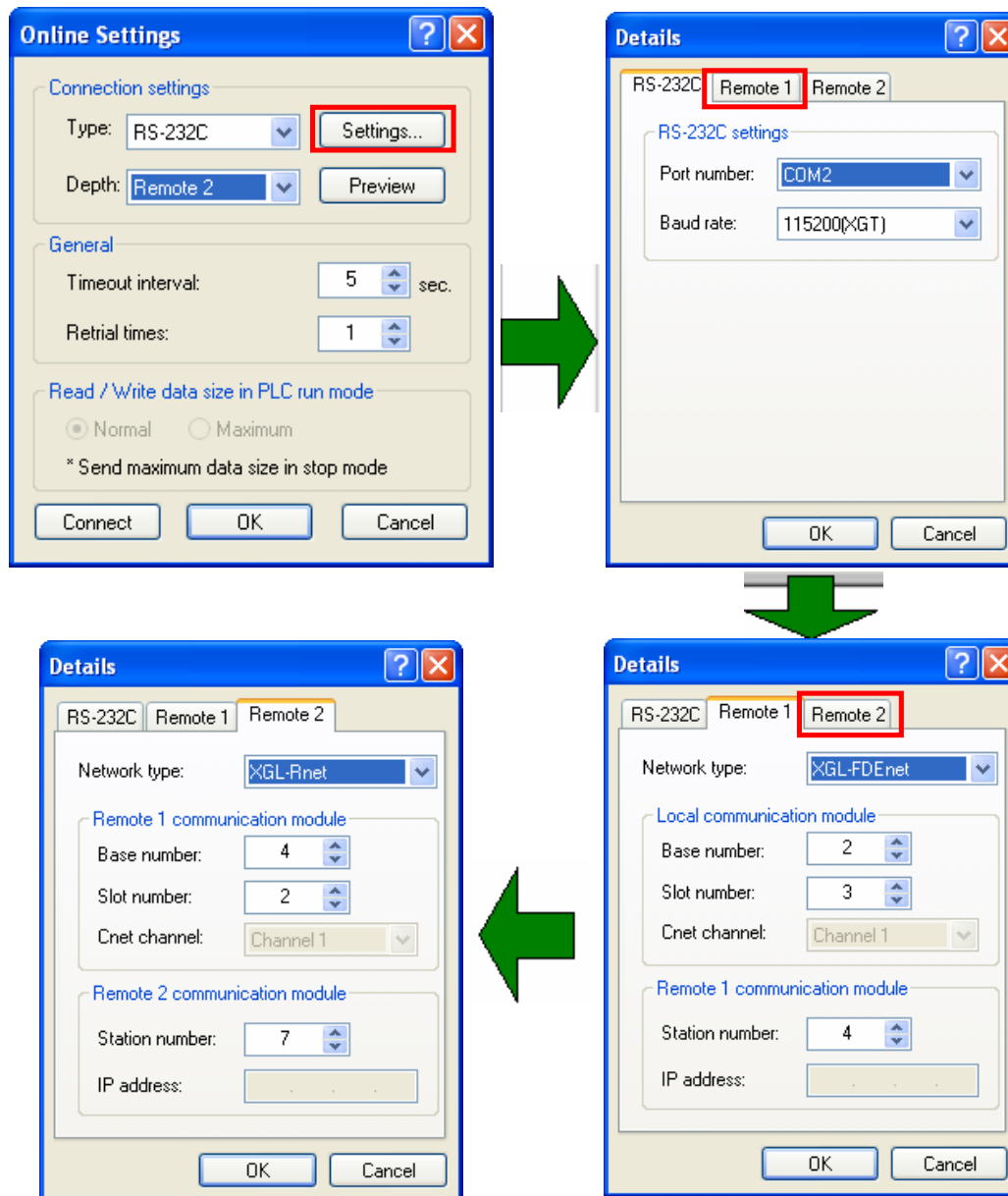

[Fig. 9-5] XG-PD remote 2

Other parts are same as the step of remote 1. Only the step of remote 2 explains.

- (1) Network type setting
 - (a) Select XGT FENet by network remote 2.
 - (b) Network type of remote 1 and remote 2 have no relevance.
- (2) Slot No. setting
 - (a) In Network 2 , the position of module which installed in remote 2 station PLC(PLC B).
 - (b) The position shall be inputted as Slot No.
- (3) The status of finishing remote 1 is same as the logical connection status with local connection by moving RS-232C. User can use all function of online menu.

9.2.3 Direct remote 1 on Enet connecting PC

When a PC with operating XG-PD connects to PLC on network, remote 1 by Enet is available without connecting RS-232C to PLC CPU.

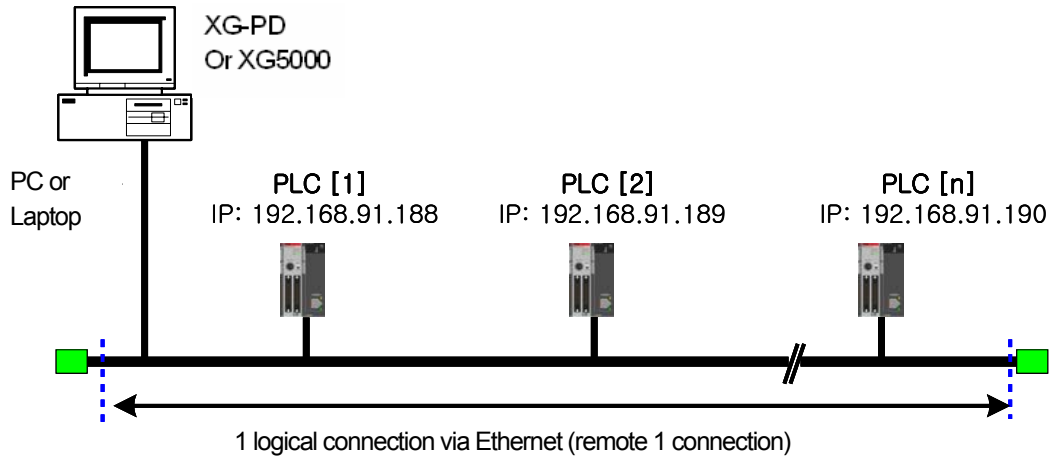

[Fig. 9-6] Remote 1 system through PC

[Fig. 9-6] shows the status that PC and PLC are connected by Enet. In this case, XG-PD can connect all PCs on network without using RS-232C. Local connection is not needed, remote 1 can be executed for all PLCs.

To execute direct remote 1 through Enet, select connection option and change the settings as following boxes.

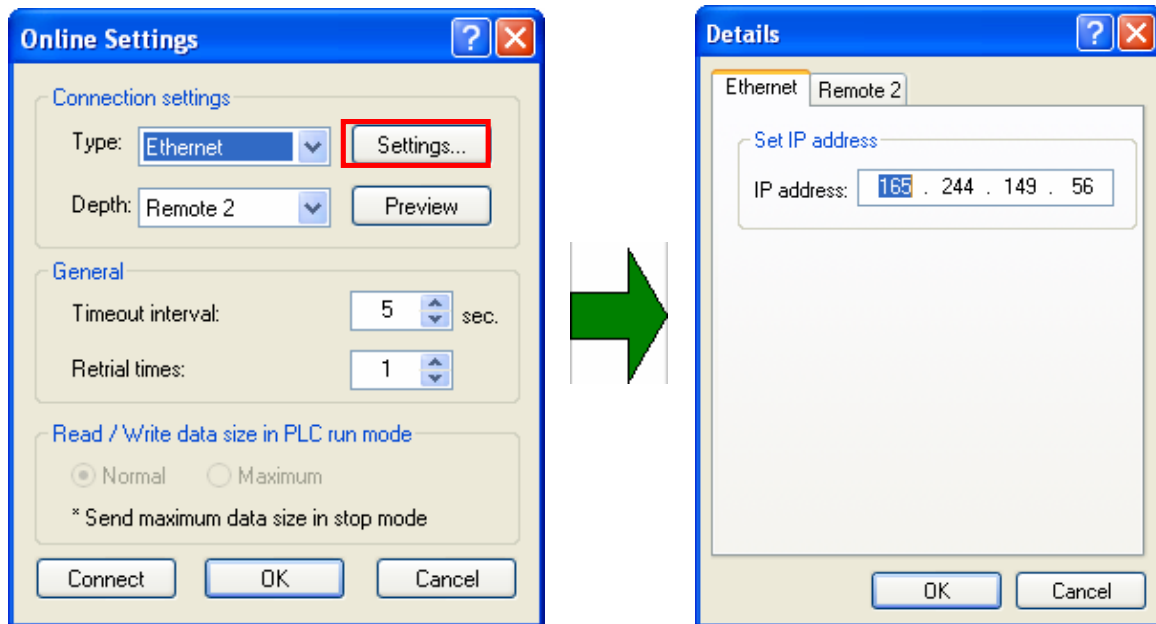

[Fig. 9-7] Direct remote 1 on PC

- (1) Connecting type
 - (a) Select connecting type. [Fig. 9-7] shows the Enet connection without using RS-232C. Select Enet.
- (2) Connection stage
 - (a) Decide remote 1 or remote 2 for the connection with PLC. In this case, select remote 1.
- (3) IP address
 - (a) Record IP address of FEnet I/F module for connection.
- (4) After(3), all steps are same as the steps of the case using RS-232C. Select enter at this status, select connection on online menu.

9.2.4 Direct remote 2 on Enet connecting PC

Remote 2 is available by using Enet, the step is same as that of remote 1. Example of setting connection option is as following.

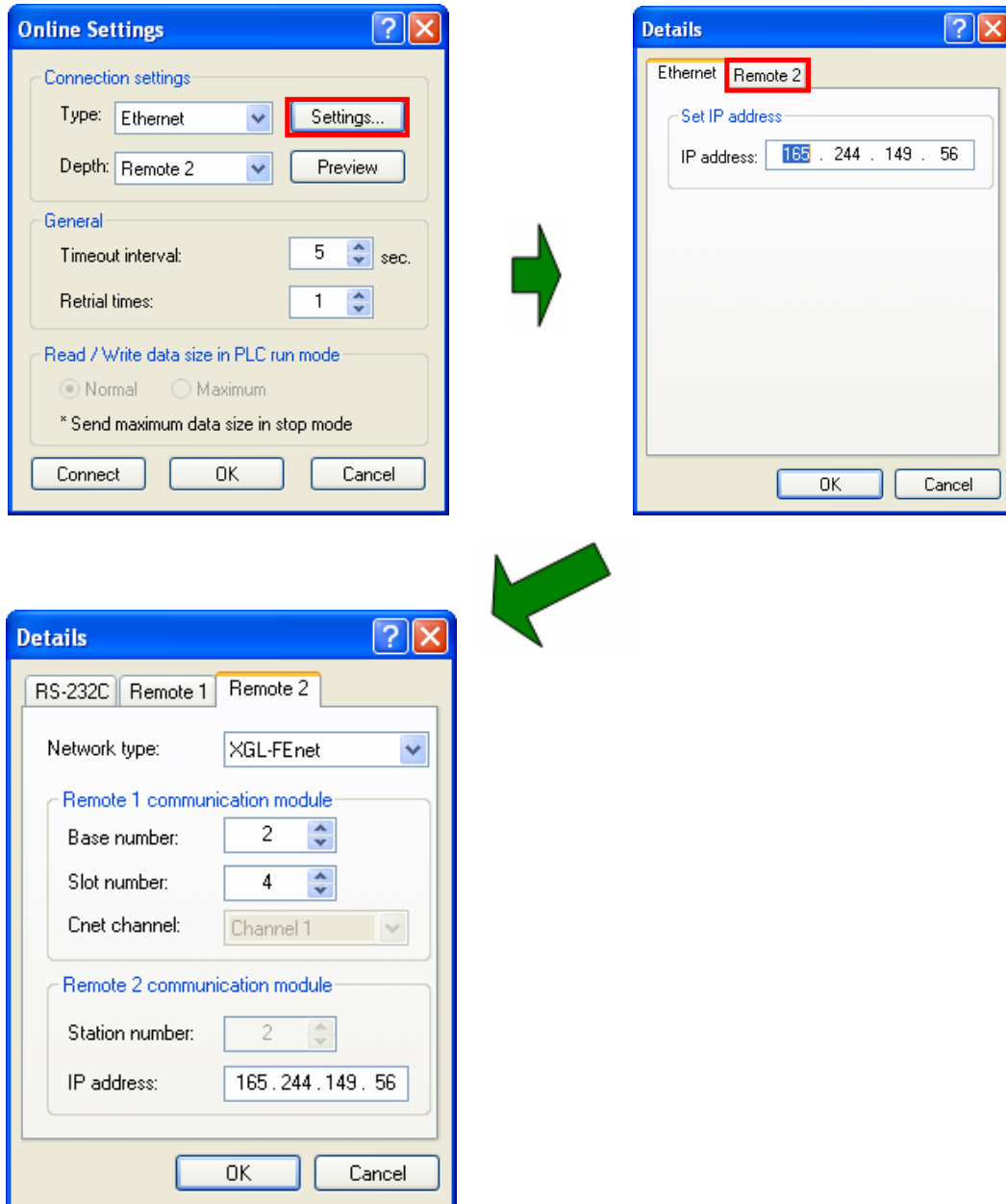

[Fig. 9-8] Direct remote 2 from on PC

Remark

- 1) Cautions for Remote 1 connection and Remote 2 connection
 - (1) Following menu item can't be available when XG-PD present open project and remote 1 and 2 connected CPU type are not well matched.
 - a) Program and Write each parameter
 - b) Program and Read each parameter
 - c) Monitor
 - d)Set Flash memory
 - e)Enable Link setting
 - f) I/O information
 - g) Force I/O
 - h) Skip I/O
 - (2) In case of programming by connecting XG-PD as remote 1 and 2, open the right project of connecting station and then execute connection.
 - (3) Remote connection provides only by remote 2. Over remote 2 is not available.

Chapter 10 Troubleshooting

This chapter describes defects and errors that may occur in system operation, their causes and actions to take against. If any error occurs on XGB Fast Enet I/F module, its related details can be checked through the procedures below. Any discretionary or disassembly is not allowed.

Error Details	Actions
RUN LED 'Off' after module powered on	1. Check if CPU unit's correctly connected with FEnet module.
	2. Check the upper and lower fixing lever position. Position close after connecting module. ☞ Connecting with CPU unit is not correct, the power can be supplied and module can't operate.
	3. Check voltage (DC 24V) and capacity of power. ☞ When the consumption current of expansion module on CPU unit is over the rated capacity, module can't operate.
	4. Check if communication module is correctly recognized through XG-PD. ☞ Check it by using system diagnosis.
I/F LED 'No-Flicker' or 'Off' after module powered on	1. Check if CPU unit's correctly connected with FEnet module. ☞ Connecting with CPU unit is not correct, data can't be exchanged normally.
	2. Check if communication module is correctly recognized through XG-PD. ☞ Check it by using system diagnosis.
TX/RX LED 'No-Flicker' or 'Off' after network connection	1. Check communication cable and network status 2. Check if RJ45 connector connected correctly 3. Check if LINK LED flicker ☞ Connection of communication cable and RJ45 connector are not correct, Send/Receive is not available.
All LEDs 'On' after module powered on	Module malfunction, Repairs should be followed
Data Read/Write unavailable during dedicated service	1. Check communication speed (Auto/10/100M-TX). Communication speed should be same as that of destination device. ☞ When the setting communication speed is as same or Auto on network, communication is available.
	2. Check IP address setting. Valid IP address on network should be set. ☞ When IP address overlapped on network or invalid IP, communication is unavailable.
	3. Check driver (Dedicated, Modbus TCP/IP) setting ☞ Same protocol with destination device should be used.
	4. Check if IP of destination device is registered on host table. ☞ When host table is enable, IP address of destination is not registered, communication is not available.
Send/Receive unavailable during HS link service	1. Check communication speed (Auto/10/100M-TX). Communication speed should be same as that of destination device. ☞ When the setting communication speed is as same or Auto on network, communication is available.
	2. Check IP address setting. Valid IP address on network should be set. ☞ When IP address overlapped on network or invalid IP, communication is unavailable.

Error Details	Actions
	<p>3. Check if HS link parameter setting</p> <ul style="list-style-type: none"> ☞ When parameter's not set, station no. is overlapped, wrong block setting, wrong block no., communication is not available. <p>4. Check link enable setting</p> <ul style="list-style-type: none"> ☞ With link enable setting, frame can be sent.
Send/Receive unavailable during P2P service	<p>1. Check communication speed (Auto/10/100M-TX)</p> <ul style="list-style-type: none"> ☞ When the setting communication speed is as same or Auto on network, communication is available.
	<p>2. Check IP address setting</p> <ul style="list-style-type: none"> ☞ When IP address overlapped on network or invalid IP, communication is unavailable.
	<p>3. Check if P2P parameter setting</p> <ul style="list-style-type: none"> ☞ Setting P2P parameter channel, block makes communication available.
	<p>4. Check destination IP address in P2P channel setting</p> <ul style="list-style-type: none"> ☞ When IP address of destination device is invalid, communication is not available.
	<p>5. Check driver setting</p> <ul style="list-style-type: none"> ☞ When communication protocol is same as destination device on the right channel, communication is available.
	<p>6. Check link enable setting</p> <ul style="list-style-type: none"> ☞ With link enable setting, frame can be sent.
	<p>7. Check if operation of operation condition</p> <ul style="list-style-type: none"> ☞ Setting operation condition should be 'On'.
	<p>8. Check operation mode of CPU</p> <ul style="list-style-type: none"> ☞ Operation condition of CPU should be 'On'.

Warranty

Warranty

1. Warranty Period

The product purchased will be guaranteed for a period of 18 months upon manufactured.

2. Warranty Coverage

Against the defect found during the Warranty Period specified above, this product will be repaired or exchanged partially. However, please understand that such cases as described below will be excluded from the Warranty Coverage.

- (1) If the defect is caused by unsuitable condition, environment and treatment or other reason than specified in the user's manual.
- (2) If the defect is caused by other parts than LS product.
- (3) If the product is remodeled or repaired by others than LS or its designated service center.
- (4) If the product is used with other procedures than originally intended.
- (5) If the defect is caused by a reason unexpected under the scientific and technical standard when released from LS.
- (6) If the defect is caused by a natural calamity or fire which LS is not responsible for.

3. Since the warranty details above are to guarantee the PLC unit only, the customers are strongly recommended to use the product after due consideration of safety for system configuration or product application.

Environmental Policy

LS Industrial Systems Co., Ltd supports and observes the environmental policy as below.

Environmental Management

LS Industrial Systems considers the environmental preservation as the preferential management subject and every staff of LS Industrial Systems use the reasonable endeavors for the pleasurable environmental preservation of the earth.

About Disposal

LS Industrial Systems' PLC unit is designed to protect the environment. For the disposal, separate aluminum, iron and synthetic resin (cover) from the product as they are reusable.