

Inductive sensor
With increased switching distance
NI8-M12-VP6X 7M

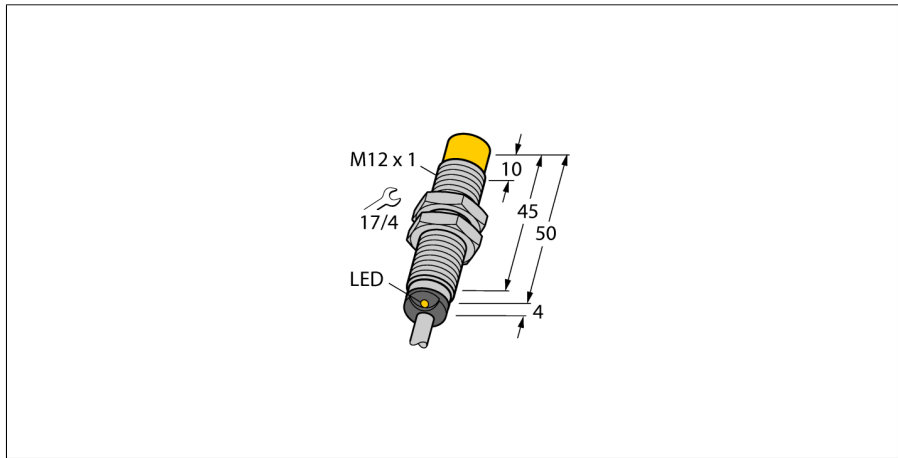

- **M12 × 1 threaded barrel**
- **brass, chrome-plated**
- **Large sensing range**
- **DC 4-wire, 10...30 VDC**
- **Changeover contact, PNP output**
- **Cable connection**

Wiring Diagram

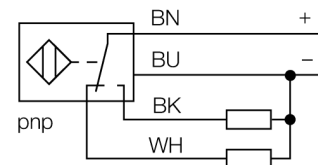

Functional principle

Inductive sensors detect metal objects contactless and wear-free. For this, they use a high-frequency electromagnetic AC field that interacts with the target. Inductive sensors generate this field via an RLC circuit with a ferrite coil.

Type designation	NI8-M12-VP6X 7M
Ident no.	4611327
Rated switching distance Sn	8 mm
Mounting conditions	Non-flush
Secured operating distance	≤ (0,81 x Sn) mm
Correction factors	St37 = 1; Al = 0.3; stainless steel = 0.7; Ms = 0.4
Repeat accuracy	≤ 2 % of full scale
Temperature drift	≤ ± 10 %
Hysteresis	3...15 %
Ambient temperature	-25...+70 °C
Operating voltage	10...30 VDC
Residual ripple	≤ 10 % U _{ss}
DC rated operational current	≤ 200 mA
No-load current I ₀	≤ 15 mA
Residual current	≤ 0.1 mA
Isolation test voltage	≤ 0.5 kV
Short-circuit protection	yes/ Cyclic
Voltage drop at I _e	≤ 1.8 V
Wire breakage/Reverse polarity protection	yes/ Complete
Output function	4-wire, Complementary contact, PNP
Reverse polarity protection	Complete
Switching frequency	2 kHz
Design	Threaded barrel, M12 × 1
Dimensions	54 mm
Housing material	Metal, CuZn, Chrome-plated
Active area material	Plastic, PA12-GF30
End cap	Plastic, EPTR
Max. tightening torque housing nut	10 Nm
Electrical connection	Cable
Cable quality	5.2 mm, LifYY, PVC, 7m
Cable cross section	4 x 0.34 mm ²
Vibration resistance	55 Hz (1 mm)
Shock resistance	30 g (11 ms)
Protection class	IP67
MTTF	2283 years acc. to SN 29500 (Ed. 99) 40 °C
Switching state	LED yellow

**Inductive sensor
With increased switching distance
NI8-M12-VP6X 7M**

Distance D	3 x B
Distance W	3 x Sn
Distance T	45 mm
Distance S	6 mm
Distance G	6 x Sn
Distance N	2 x Sn
<hr/>	
Diameter active area B	Ø 12 mm



**Inductive sensor
With increased switching distance
NI8-M12-VP6X 7M**

Accessories

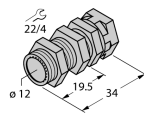
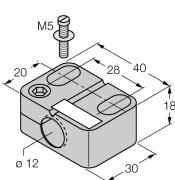
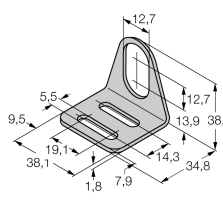
Type code	Ident no.	Description	
QM-12	6945101	Quick-mount bracket with dead-stop; material: Chrome-plated brass Male thread M16 x 1. Note: The switching distance of proximity switches can be reduced by the use of quick-mount brackets.	
BST-12B	6947212	Fixing clamp for threaded barrel devices, with dead-stop; material: PA6	
MW-12	6945003	Mounting bracket for threaded barrel devices; material: Stainless steel A2 1.4301 (AISI 304)	
BSS-12	6901321	Mounting bracket for smooth and threaded barrel devices; material: Polypropylene	