

RS485 IO Slim Module MOD-ETH

Expansion Module – gateway Modbus TCP

Version 1.6

User Manual



Manufactured for

aspar

CE

Thank you for choosing our product.

This manual will help you with proper support and proper operation of the device.

The information contained in this manual have been prepared with utmost care by our professionals and serve as a description of the product without incurring any liability for the purposes of commercial law.

This information does not release you from the obligation of own judgement and verification.

We reserve the right to change product specifications without notice.

Please read the instructions carefully and follow the recommendations contained therein.

**WARNING!**

Failure to follow instructions can result in equipment damage or impede the use of the hardware or software.

1. Safety rules

- Before first use, refer to this manual;
- Before first use, make sure that all cables are connected properly;
- Please ensure proper working conditions, according to the device specifications (eg: supply voltage, temperature, maximum power consumption);
- Before making any modifications to wiring connections, turn off the power supply.

2. Module Features

2.1. Purpose and description of the module

ETH module is an innovative device converting Modbus TCP into Modbus RTU/ASCII.

The device has the Ethernet and RS485 interface, 4 digital inputs with counters and 3 relay outputs. All the inputs are insulated from logic with the aid of optoisolators.

The communication takes place with the benefit of Modbus TCP protocole. Every received request from the Modbus TCP client is checked considering the address. If the address is different than the MOD-ETH device address, automatic conversion of the request frame into the Modbus RTU/ASCII protocole ensues. Later on, the correctly received answer is sent to the Modbus TCP client.

The usage of a 32-bit processor with ARM core assures fast data processing and smart communication.

The new function called Modbus Device Table allows the user to define their own enquiries to Modbus ATU/ASCII from the accessible internal registries of the device. This function allows to e.g. automatic reading of the statuses of the modules' inputs on RS485 and inscribing these statuses into the MOD-ETH internal registries. Internal registries are accessible for the Modbus TCP clients without additional delays resulting from the RS485 magistral line. This solution strongly accelerates the communication. All the bit orders and registry orders of the MODBUS protocole are available.

The module is designed for mounting on a DIN rail in accordance with DIN EN 5002.

The module is equipped with a set of LEDs used to indicate the status of inputs and outputs useful for diagnostic purposes and helping to find errors.

Module configuration is done via built-in website or USB by using a dedicated computer program. You can also change the parameters using the MODBUS protocole.

2.2. Technical Specifications

Power Supply	Voltage	10-38VDC; 10-28VAC
	Maximum Current	360 mA @ 12V / 300 mA @ 24V
Digital inputs	No. of inputs	4
	Voltage range	0 - 36V
	Low state „0”	0 - 3V
	High state „1”	4 - 36V
	Input impedance	4k Ω
	Isolation	3750 Vrms
	Inputs type	PNP lub NPN
Counters	No.	4
	Resolution	32 bits
	Frequency	1kHz (max)
	Impulse Width	500 μ s (min)
Relay outputs	No. of outputs	3
	Maximum current and voltage (resistive load)	3A 230VAC 3A 30VDC
Temperature	Work	-10 °C - +50°C
	Storage	-40 °C - +85°C
Connectors	Power supply	2 pins
	Communication RS485	3 pins
	Communication Ethernet	RJ45
	Inputs and outputs	2 x 5 pin
	Quick connector	IDC10
	Configuration	Mini USB
Size	Height	120 mm
	Length	110 mm
	Width	22,5 mm
Interface	Ethernet	10/100 Mbps
	RS485	Up to 128 devices

2.3. Dimensions of the product

Look and dimensions of the module are shown below. The module is mounted directly to the rail in the DIN industry standard. Power connectors, communication and IOs are at the bottom and top of the module. USB connector configuration and indicators located on the front of the module.

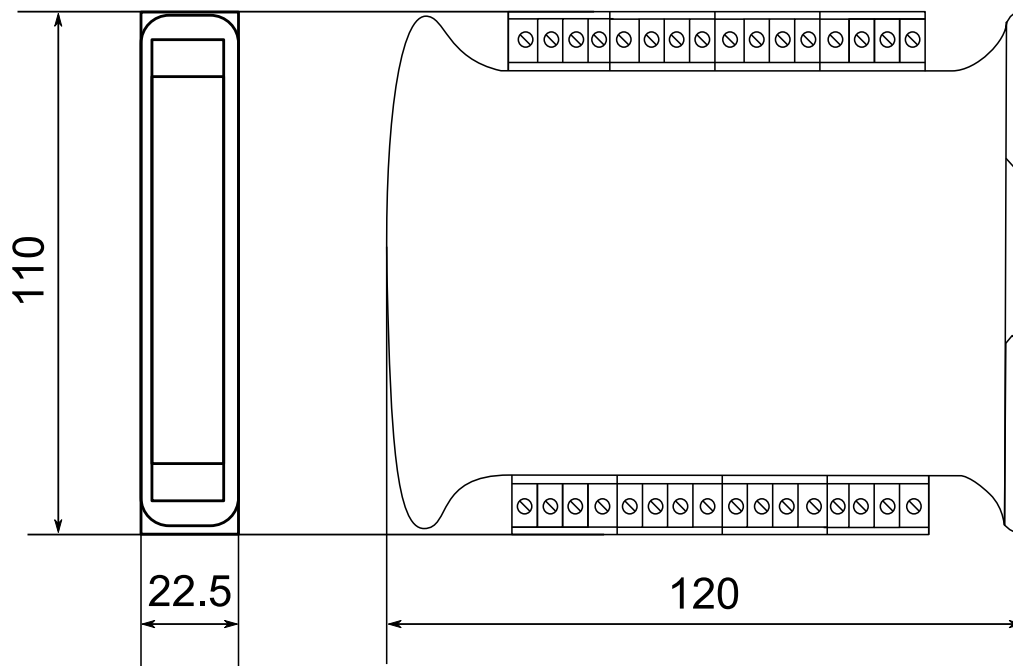

3. Communication configuration

3.1. Grounding and shielding

In most cases, IO modules will be installed in an enclosure along with other devices which generate electromagnetic radiation. Examples of these devices are relays and contactors, transformers, motor controllers etc. This electromagnetic radiation can induce electrical noise into both power and signal lines, as well as direct radiation into the module causing negative effects on the system. Appropriate grounding, shielding and other protective steps should be taken at the installation stage to prevent these effects. These protective steps include control cabinet grounding, module grounding, cable shield grounding, protective elements for electromagnetic switching devices, correct wiring as well as consideration of cable types and their cross sections.

3.2. Network Termination

Transmission line effects often present a problem on data communication networks. These problems include reflections and signal attenuation.

To eliminate the presence of reflections from the end of the cable, the cable must be terminated at both ends with a resistor across the line equal to its characteristic impedance. Both ends must be terminated since the direction of propagation is bi-directional. In the case of an RS485 twisted pair cable this termination is typically 120 Ω.

3.3. Setting Module Address in RS485 Modbus Network

Changing the address of the MOD-ETH is possible with the aid of an inbuilt www website. After logging in, one should choose the tab Network, put the module address in the Device Address field and click Save. The device will save the given address and will remember it even after disconnecting from the power supply (more details in 11.4 - Modbus Config).

Attention! The address is reset during the restoration of default configuration (more details in 3.5.1 – Default settings).

3.4. Types of Modbus Registers

There are 4 types of variables available in the module

Type	Beginning address	Variable	Access	Modbus Command
1	00001	Digital Outputs	Bit Read & Write	1, 5, 15
2	10001	Digital Inputs	Bit Read	2
3	30001	Input Registers	Registered Read	3
4	40001	Output Registers	Registered Read & Write	4, 6, 16

3.5. Communication settings

The settings of TCP communication are stored in memory of the device. The Modbus TCP network configuration is only accessible through the www website (more details in 9.3. – Network). The data of the communication of the module in RS485 network is stored in 16-bit registries. The access to the registries is possible with the benefit of Modbus TCP protocol or through the www website (szczegóły w 11.4 - Modbus Config).

3.5.1. Default settings

You can restore the default configuration by the switch SW6 (see 3.5.2 - Restore the default configuration).

Modbus TCP		Modbus RTU/ASCII	
Address IP	192.168.1.135	Transmission speed	19200
Mask	255.255.255.0	Parity	Nie
Gateway	192.168.1.1	The amount of data bits	8
Port Modbus	502	The amount of stop bits	1
Port HTTP	80	Modbus mode	RTU
Timeout of connection	60 s	The device address	1
Login	admin	Timeout of RS485	500 ms
Password	0000	Mode	Brama
		Device Table Refresh Slow	10000 ms
		Device Table Refresh Normal	2000 ms
		Device Table Refresh Fast	500 ms

3.5.2. Restore the default configuration

To restore the default configuration:

- turn off the power
- turn on the switch SW6
- turn on the power
- when power and communication LED flash turn off the switch SW6

Caution! After restoring the default configuration all values stored in the registers will be cleared as well.

3.5.3. Configuration registers

Address Modbus	Address Dec	Address Hex	Name	Values
40003	2	0x02	Baud rate	0 – 2400 1 – 4800 2 – 9600 3 – 19200 4 – 38400 5 – 57600 6 – 115200 other – value * 10
40005	4	0x04	Parity	0 – none 1 – odd 2 – even 3 – always 1 4 – always 0
40004	3	0x03	Stop Bits LSB	1 – one stop bit 2 – two stop bits
40004	3	0x03	Data Bits MSB	7 – 7 data bits 8 – 8 data bits
40007	6	0x06	Modbus Mode	0 – RTU 1 – ASCII

3.5.4. Watchdog function

This 16-bit register specifies the time in milliseconds to watchdog reset. If module does not receive any valid message within that time, all Digital and Analog Outputs will be set to the default state.

This feature is useful if there is an interruption in data transmission and for security reasons. Output states must be set to the appropriate state in order to assure the safety of persons or property.

The default value is 0 milliseconds which means the watchdog function is disabled.

Range: 0-65535 ms

4. Indicators

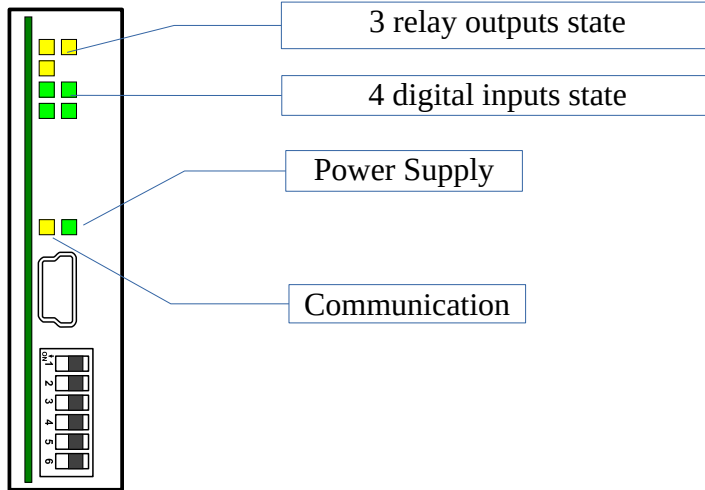

Indicator	Description
Power supply	LED indicates that the module is correctly powered.
Communication	The LED lights up when the unit received the correct packet Modbus TCP, converted to Modbus RTU/ASCII and sent it over the RS485 network.
Inputs state	LED indicates that the input is on.
Outputs state	LED indicates that the output is on.

5. Block Diagram

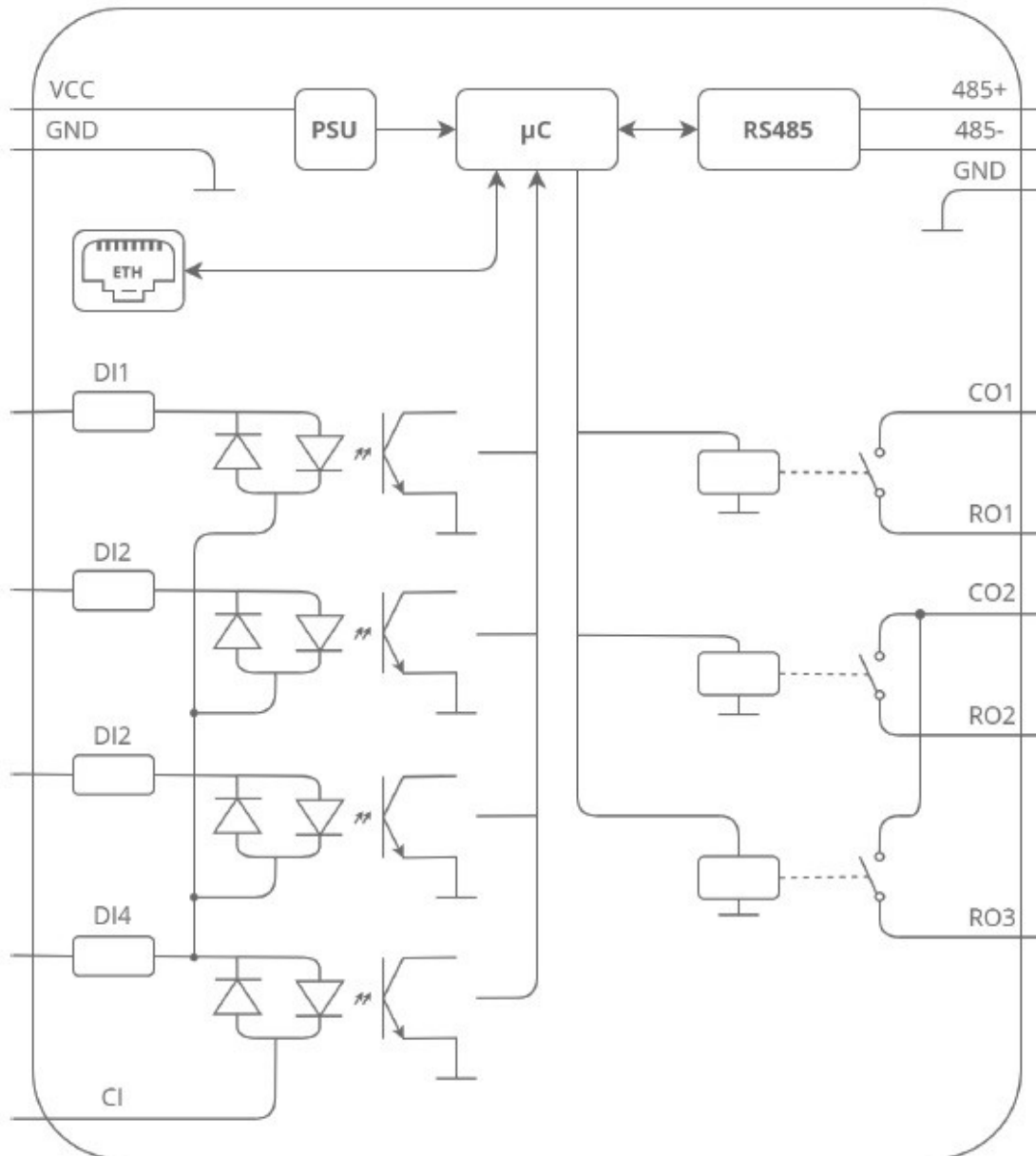

6. Module Connection

6.1. Digital inputs

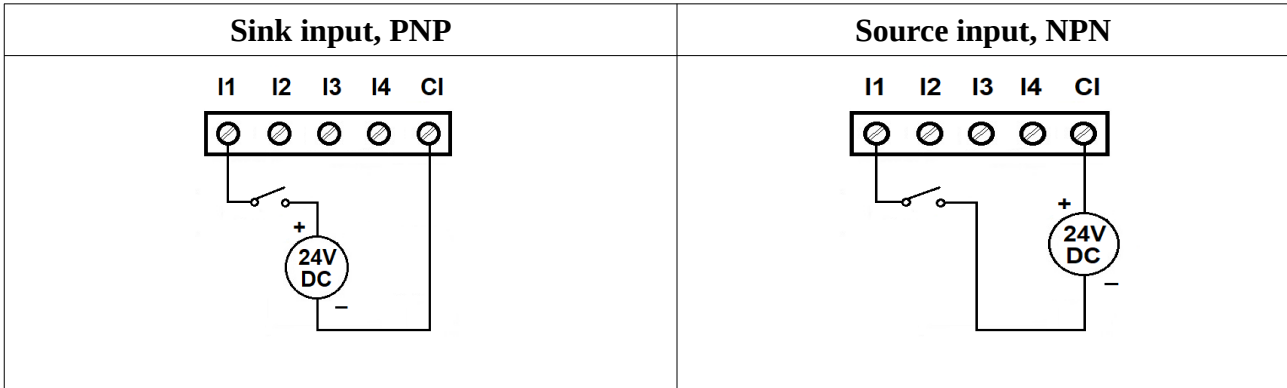

6.2. Relay outputs

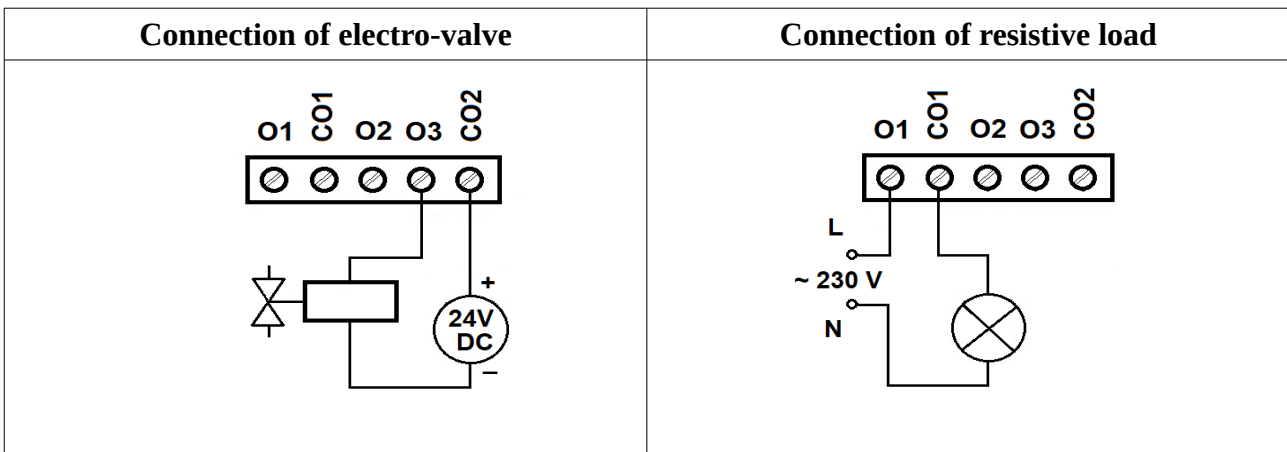

6.3. Communication, power supply

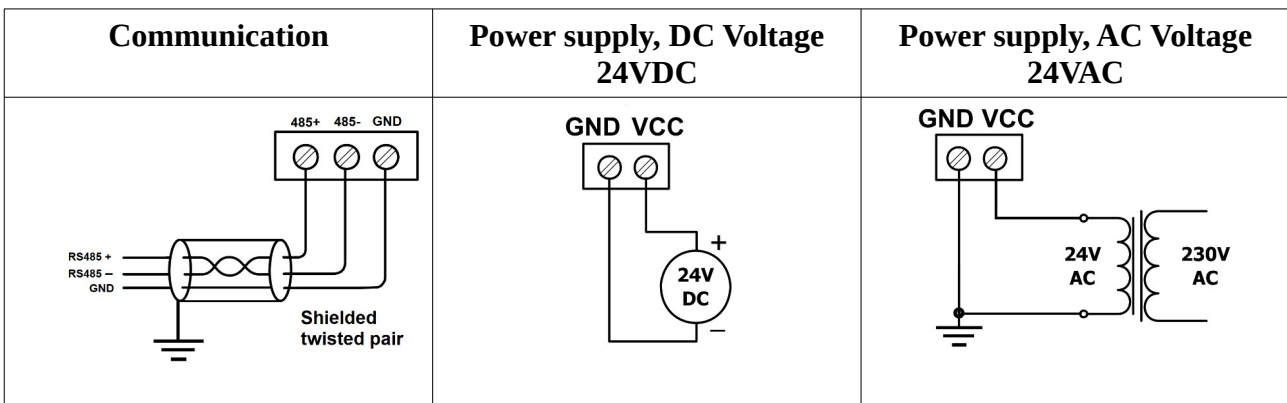

6.4. Quick connector

Quick Connector is an unique feature of modules that allows you to quickly connect group of devices with a flat ribbon cable MOD-QC. Thanks to this solution, it is enough to connect power and RS485 communication to one of the devices in the group and the others will be powered and communicated with ribbon cable.

The Quick Connector is sufficient to connect up to 10 devices next to each other. What is important that the various types of modules in the SLIM family can be connected with the ribbon cable.



7. Switches

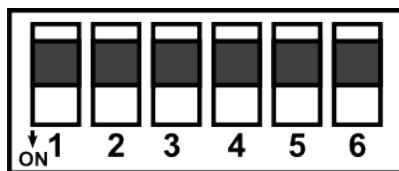

Switch	Function	Description
1	None	
2	None	
3	Bias Pull Up	Switching pull-up resistor
4	Bias Pull Down	Switching pull-down resistor
5	Network Termination	Switching terminating resistor 120Ω
6	Restoring default settings	Restoring default settings (check 3.5.1 - Default settings i 3.5.2 - Restore the default configuration).

8. Input filter

Digital inputs allow connection of the AC signal. However, due to the fact that these inputs are fast and allow counting pulses at 1 kHz frequency, it is not possible to use them to monitor the presence of a variable frequency signal like 50Hz because, depending on the moment at which the input state is read with the Modbus protocol, we can obtain different results despite the fact that AC voltage is still present. To be able to monitor the AC signals, we introduced the possibility of filtering the digital inputs. Filtration works in a way that the high state occurs if the voltage is maintained for at least 40 ms. The low state appears when there is no voltage for at least 80 ms. The filter can be turned on for each input of the device independently using the 40018 register.

We can run filters through the configuration program and directly through the registry.

9. Modules Registers

9.1. Registered access

Address Modbus	Address Dec	Address Hex	Register Name	Access	Description
30001	0	0x00	Version/Type	Read	Version and Type of the device
30002	1	0x01	Address	Read	Module address MOD-ETH
40003	2	0x02	Baud rate	Read & Write	Transmission speed
40004	3	0x03	Stop bits	Read & Write	Stop bites
40005	4	0x04	Parity	Read & Write	Bit od parity
40007	6	0x06	Modbus Mode	Read & Write	Modbus protocol type
40009	8	0x08	Watchdog	Read & Write	Function watchdog for outputs [ms]
40013	12	0x0C	Default Outputs State	Read & Write	Default state of outputs (after power on or watchdog reset)
40014	13	0x0D	Operating mode	Read & Write	Modbus mode TCP 0 – Device Table; 1 – Gateway Modbus TCP
40015	14	0x0E	Question Slow	Read & Write	Frequency question in mode Device Table [ms]
40016	15	0x0F	Question Normal	Read & Write	Frequency question in mode Device Table [ms]
40017	16	0x10	Question Fast	Read & Write	Frequency question in mode Device Table [ms]
40018	17	0x11	Inputs filter	Read & Write	Configuration of the inputs filter
40033	32	0x20	Received packets LSB	Read & Write	The amount of received packets
40034	33	0x21	Received packets MSB	Read & Write	
40035	34	0x22	Incorrect packets LSB	Read & Write	The amount of received incorrect packets
40036	35	0x23	Incorrect packets MSB	Read & Write	
40037	36	0x24	Sent packets LSB	Read & Write	The amount of sent packets
40038	37	0x25	Sent packets MSB	Read & Write	
30051	50	0x32	Inputs	Read	Connected inputs Inputs state
40052	51	0x33	Outputs	Read & Write	Alarm outputs Bit 8 and 9 digital outputs
30053	52	0x34	Counter 0 LSB	Read	32-bits counter 0
30054	53	0x35	Counter 0 MSB	Read	
30055	54	0x36	Counter 1 LSB	Read	32-bits counter 1
30056	55	0x37	Counter 1 MSB	Read	
30057	56	0x38	Counter 2 LSB	Read	32-bits counter 2
30058	57	0x39	Counter 2 MSB	Read	
30059	58	0x3A	Counter 3 LSB	Read	32-bits counter 3
30060	59	0x3B	Counter 3 MSB	Read	
40061	60	0x3C	Reset counters	Read & Write	Reset counters light bit → counter reset

9.2. Bit access

Address Modbus	Address Dec	Address Hex	Register name	Access	Description
193	192	0x0C0	Default state of output 1	Read & Write	Default state of output 1
194	193	0x0C1	Default state of output 2	Read & Write	Default state of output 2
195	194	0x0C2	Default state of output 3	Read & Write	Default state of output 3
196	195	0x0C3	Default state of output 4	Read & Write	Default state of output 4
801	800	0x320	Input 1	Read	If input is connected
802	801	0x321	Input 2	Read	If input is connected
803	802	0x322	Input 3	Read	If input is connected
804	803	0x323	Input 4	Read	If input is connected
817	816	0x330	Digital output 1	Read & Write	State of digital output 1
818	817	0x331	Digital output 2	Read & Write	State of digital output 2
819	818	0x332	Digital output 3	Read & Write	State of digital output 3
961	960	0x3C0	Reset counter 0	Read & Write	Reset counter 0
962	961	0x3C1	Reset counter 1	Read & Write	Reset counter 1
963	962	0x3C2	Reset counter 2	Read & Write	Reset counter 2
964	963	0x3C3	Reset counter 3	Read & Write	Reset counter 3

10. Configuration software

Modbus Configurator is software that is designed to set the module registers responsible for communication over Modbus network as well as to read and write the current value of other registers of the module. This program can be a convenient way to test the system as well as to observe real-time changes in the registers.

Communication with the module is done via the USB cable. The module does not require any drivers.

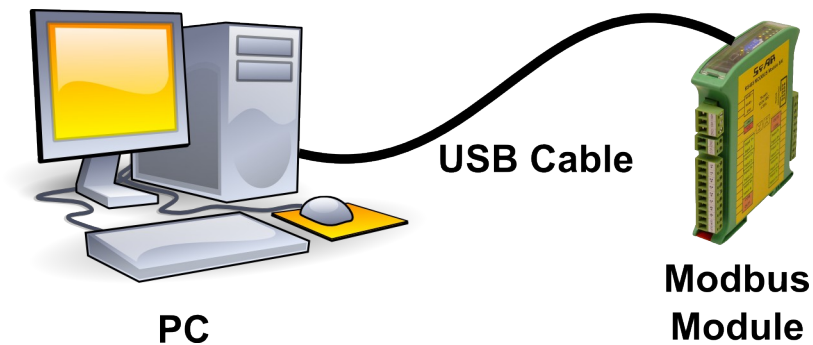

Configurator is a universal program, whereby it is possible to configure all available modules.

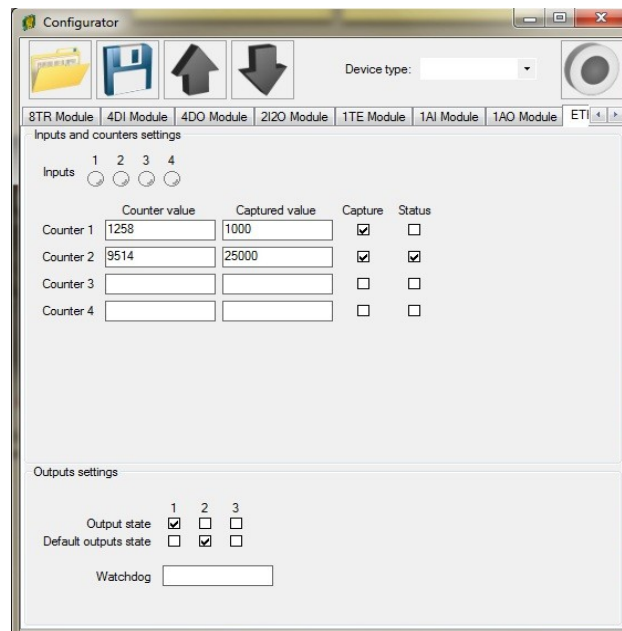

11. Web page

The MOD-ETH device has an inbuilt www website, thanks to which the user is able to control its working. The website allows to the access to the configuration of the TCP and RS485 networks, up-to-date statuses of inputs and outputs and the settings of the Device Table mode.

11.1. Login

The access to the website is possible through the browser. In the address field one should put the IP address of the device and press Enter. Then appears the log-in site, in which one should put the login 'admin' and the defined password (by default '0000'). If the login and the password are correct, after clicking the Login button appears the default www website with the Info tab opened.

The logout takes place if the default website is opened for at least 15 minutes with the tab of Info, Network or Modbus Config or after clicking the Logout button.

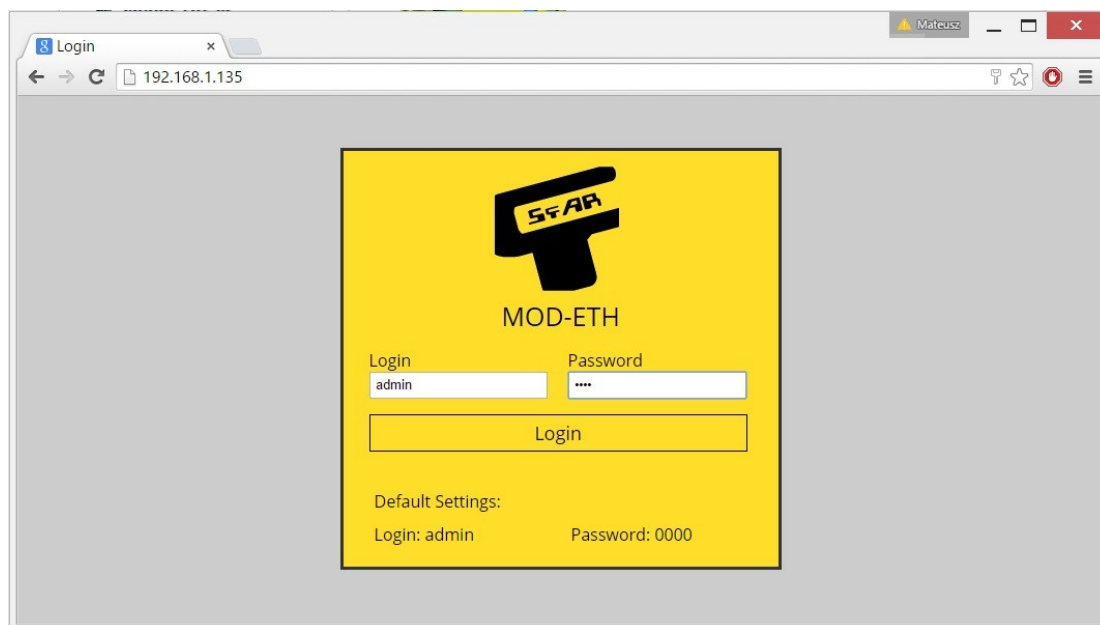

11.2. Info

The tab Info implies links to the instructions of the device and information about the up-to-date version of the software. Changing the password of the access to the www website is also possible.

In order to change the password one should put the prevailing password in the field Old Password and the new one in the fields New Password and Confirm Password. Then click the button Change Password.

Attention! After the re-enacting of default settings, the password is reset (more details in 3.5.1 - Default settings).

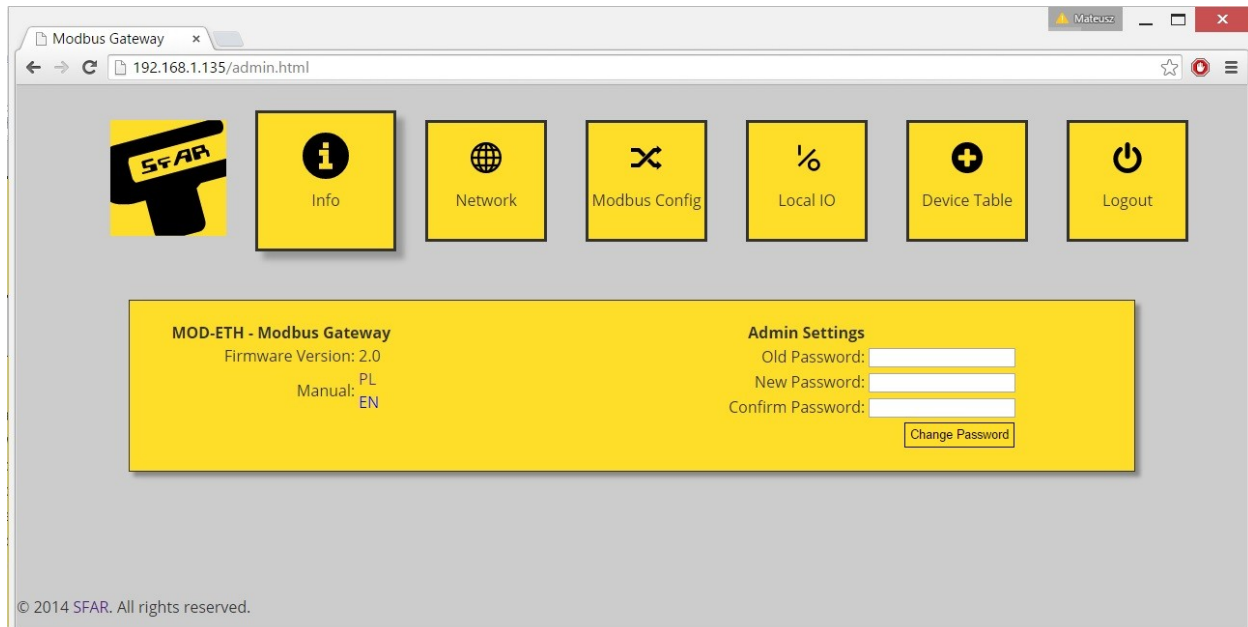

11.3. Network

The tab Network serves to the Modbus TCP network configuration. The given parameters are implied:

- IP – the module’s IP address
- Mask – the network’s mask
- Gateway – the gate
- Modbus Port – the port to connect the PC with TCP Modbus
- HTTP Port – the port to connect with www website
- Connection Timeout – the maximum waiting time for the requests TCP Modbus. After this time the connection on the Modbus Port will be cut (given in seconds).

In order to confirm the changes, one should click the Save button. In the case of changing IP, Mask, Gateway, Modbus Port and/or HTTP Port parameters, one should reset the module to let the changes be implemented. The Reset Device button has been put to remotely reset the device. After clicking on it, the browser will try to connect with the new IP address and after a few seconds the log-in website with the prevailing IP address will be loaded.

Attention! After the re-enacting the default settings, all the parameters are reset (more details in 2.5.1. – Default settings).

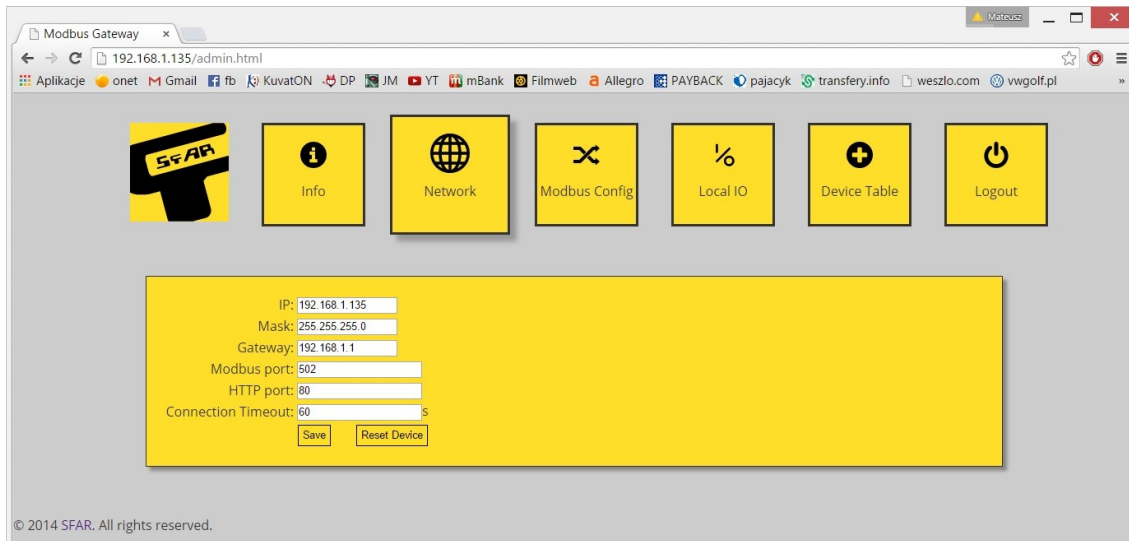

11.4. Modbus Config

In the Modbus Config tab, the configuration of the basic Modbus network parameters for both of the working modes is possible. The tab implies the parameters of RS485 network to communicate with external modules (details in 3.5.3 - Configuration registers), and:

- Device Address – the module’s address in Modbus TCP network,
- RS485 Timeout – the maximum waiting time for the response in the Modbus RTU/ASCII network (given in milliseconds),
- Device Table Refresh Slow, Normal, Fast – the frequency of refreshing the request in the Device Table mode (given in milliseconds),
- Mode – the working mode of the module (details in 12 - Modbus TCP working modes).

11.5. Local I/O

The Local I/O tab enables to see the preview and to control the digital inputs and outputs of the device.

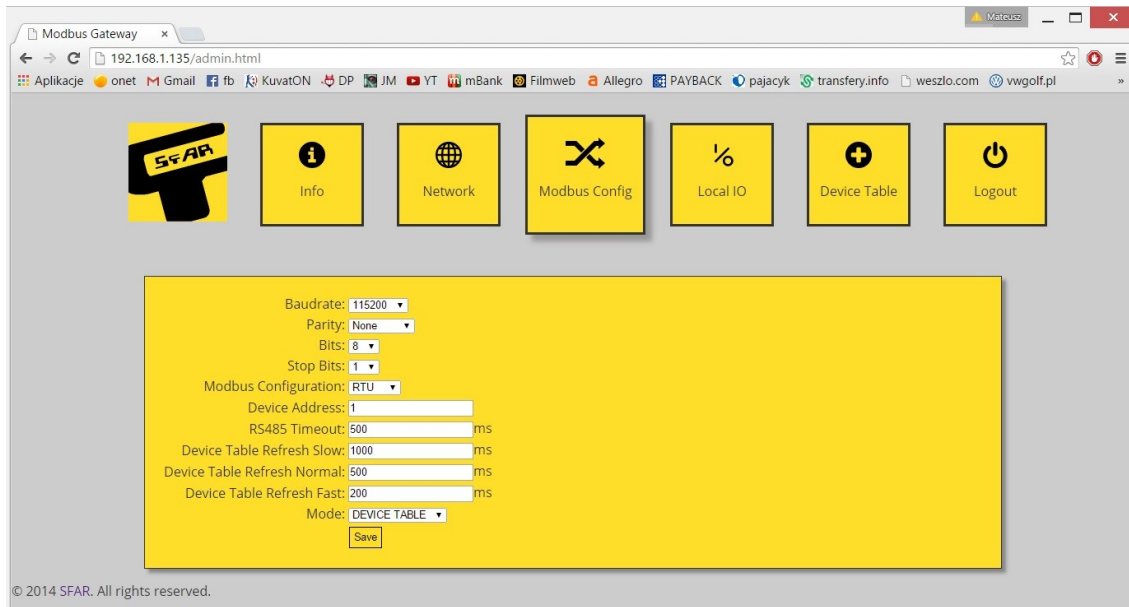

Four icons marked as Digital input 1, 2, 3, 4 show the up-to-date status of digital inputs. The grey colour indicates that the input is inactive and the green colour means that it is active.

Icons marked as Digital output 1, 2, 3 allow to control the outputs. The grey colour indicates that the particular output is off and the orange colour means that it is on. After clicking on a particular button, the information about the output's status is sent to the module.

The status of inputs and outputs is recurrently refreshed, so the icons described above present the up-to-date status of the inputs and outputs of the device.

In this tab there are also fields showing the status of 4 counters which count the impulses on the inputs 1, 2, 3 and 4. The fields are read-only and the counters can be only reset with the aid of the corresponding Reset buttons.

The module also permits to define default statuses of the outputs. On the www website they can be set analogously to the digital outputs – the grey colour indicates that the default output is off and the orange colour means that it is on. The default status is assigned after connecting to a power supply and after the Watchdog time elapse, which is reset after each correct TCP Modbus package addressed to the MOD-ETH module. If the Watchdog's value equals zero, the default statuses are only assigned after connecting the power supply.

11.6. Device Table

The next tab includes configurations for the Device Table mode, which allows to define one's own requests Modbus RTU/ASCII from the accessible internal registers of the device.

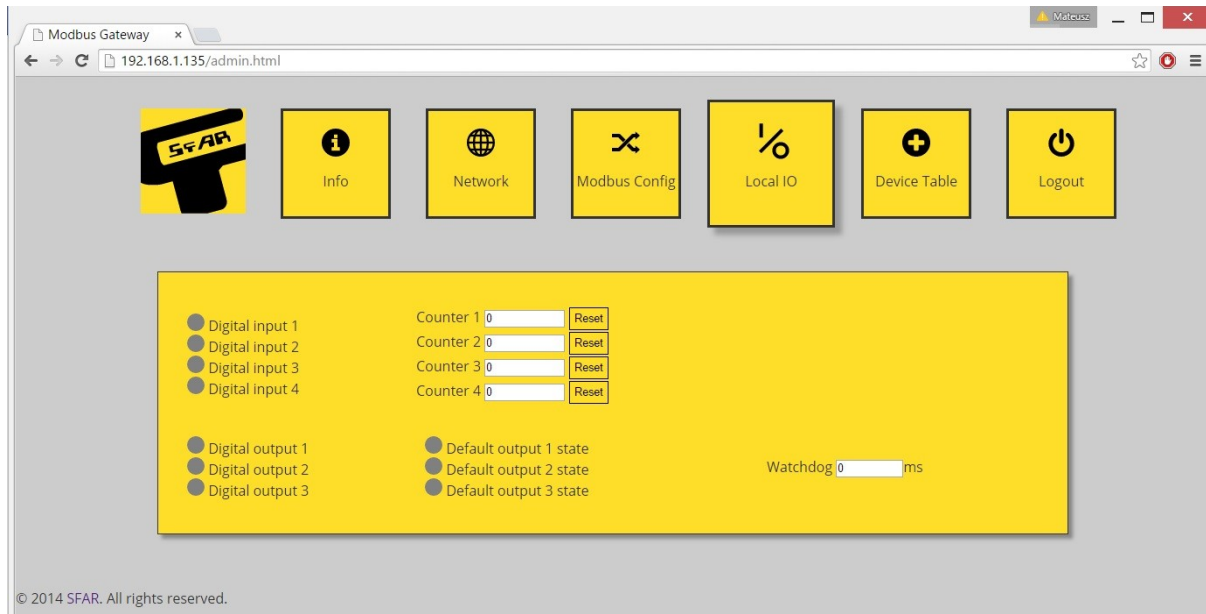

The first tab called Internal Registers includes the table of internal registers of the MOD-ETH module, which are recurrently refreshed by www website. These registers are used by adding remote requests in the Devices tab. After clicking on the Add Device button, a line to define the request appears. Each line implies the following information:

- Device Address – the address of the device in RS485 network, to which the MOD-ETH module will send the request,
- Function – the Modbus request function,
- Size – the amount of bits/registers to read/save
- Register Address – the address of the initial register,
- Internal Address – the initial address of the internal register, where the data to save/read will be stored,
- Speed – the choice of one of the three frequencies read (the values are configurable in the module's registers),
- ON/OFF – the active or inactive request,
- Status – presents the status of the request.

The configuration of the requests can be saved by the user in an external file and after read and automatically re-enacted to the device. The configuration is saved in the memory of the device and is only reset after re-enactment of the default configuration (more details in 3.5.1 - Default settings).

The screenshot shows a web browser window titled 'Modbus Gateway' with the URL '192.168.1.135/admin.html'. The interface features a navigation bar with icons for 'Info', 'Network', 'Modbus Config', 'Local IO', 'Device Table', and 'Logout'. The main content area is titled 'Devices' and contains a table with the following columns: Device Address, Function, Size, Register Address, Internal Address, Speed, ON/OFF, Delete Device, and Status.

Device Address	Function	Size	Register Address	Internal Address	Speed	ON/OFF	Delete Device	Status
2	(0x01) Read Coils	1	1	1000	Slow	ON	Delete	Not responding
3	(0x04) Read Input Registers	1	0	1010	Normal	ON	Delete	Not responding
4	(0x06) Write Single Register	1	51	1020	Fast	ON	Delete	Not responding
5	(0x02) Read Discrete Inputs	1	0	1005	Slow	OFF	Delete	Device turned off

At the bottom of the table area, there are buttons for 'Add Device', 'Save Config', and 'Load Config'. A copyright notice at the bottom left reads: '© 2014 SFAR. All rights reserved.'

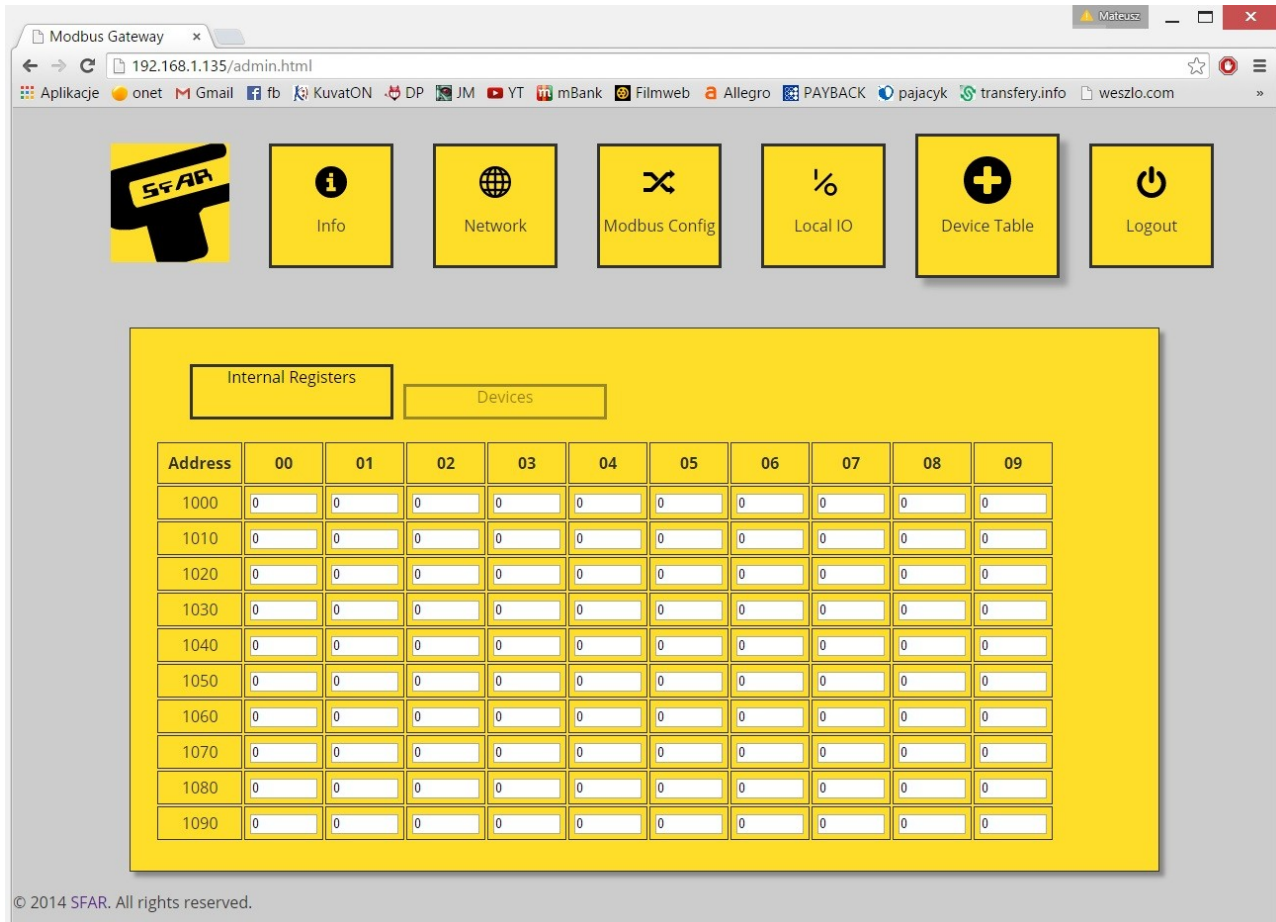

12. Modbus TCP working modes

The MOD-ETH module has two different working modes. The first is the TCP Modbus gate, in which the device converts the frames of Modbus TCP into Modbus RTU/ASCII and sends them to the RS485 network's devices.

The second mode is the Device Table function, in which the module read the RS485 network's devices only using the earlier-defined requests and ignores the requests addressed to other devices in the Modbus TCP network. The communication with external modules is only possible through the internal registers of the module from the addresses 1000-1099.

12.1. Gateway Modbus TCP

The MOD-ETH module in the TCP gate mode serves maximum up to four clients simultaneously. After connecting to the module in the proper port, the module waits for the frames which are compatible with the Modbus TCP specification. In the first instance, after receiving any package on this port, the device checks its correctness. If

the length of the package will be uncorrect, the device will send an error with the Modbus code 0x03 – Illegal Data Value. If the request is correct and addressed to the MOD-ETH module, the function from the request is executed. If it is not a Modbus function, the device will send the error with the code 0x04 – Server Device Failure.

After processing the request and preparing the response, the module sends it accordingly to the Modbus TCP protocol's specification.

If the request is not addressed to the MOD-ETH module and the TCP gate mode is set, the device converts the request into the Modbus RTU/ASCII and sends it to RS485 magistral line. The MOD-ETH waits for the defined time for the response and blocks the access to the RS485 magistral line for other clients, to avoid the packages' conflict. If the module receives the response or the time is out, the magistral line is released and in the case of receiving the package on the RS485 it is checked in terms of compatibility with the RTU or ASCII mode. In the case of a correct package, it is converted into Modbus TCP and sent to the client. In the case of an error, the code 0x04 (if the response was not received before the defined time) or the code 0x03 (if the package is incorret) is sent. If the module does not get the access to the RS485 network, the package is sent back with the error code 0x06 – Server Device Busy.

12.2. Device Table

While working in the Device Table mode, the client connects with the device in the same way as in the case of the gate mode. One considerable difference is that the MOD-ETH module will ignore all the requests which are not addressed to it. The communication with external devices is only possible through the configuration of remote requests by the www website (more details in 9.6 – Device Table) and reading/saving from/to the internal registers of the MOD-ETH module. Each request is automatically stored in the module's memory.

If the configuration of the request is correct, the device in this mode asks the modules online by saving the request and it saves the responses in the internal registers indicated by the user in the case of reading the data or downloads the data from there registers in the case of their saving. In the case of uncorrectly configured request or when there is no response from the device, an appropriate communicate is shown on the website in the Devices tab, in the Status column.

Table of Contents

1. Safety rules.....	3
2. Module Features.....	3
2.1. Purpose and description of the module.....	3
2.2. Technical Specifications.....	4
2.3. Dimensions of the product.....	5
3. Communication configuration.....	5
3.1. Grounding and shielding.....	5
3.2. Network Termination.....	6
3.3. Setting Module Address in RS485 Modbus Network.....	6
3.4. Types of Modbus Registers.....	6
3.5. Communication settings.....	6
3.5.1. Default settings.....	7
3.5.2. Restore the default configuration.....	7
3.5.3. Configuration registers.....	8
3.5.4. Watchdog function.....	8
4. Indicators.....	9
5. Block Diagram.....	10
6. Module Connection.....	11
6.1. Digital inputs.....	11
6.2. Relay outputs.....	11
6.3. Communication, power supply.....	11
6.4. Quick connector.....	12
7. Switches.....	12
8. Input filter.....	13
9. Modules Registers.....	14
9.1. Registered access.....	14
9.2. Bit access.....	15
10. Configuration software.....	16
11. Web page.....	17
11.1. Login.....	17
11.2. Info.....	17
11.3. Network.....	18
11.4. Modbus Config.....	19
11.5. Local I/O.....	20
11.6. Device Table.....	21
12. Modbus TCP working modes.....	23
12.1. Gateway Modbus TCP.....	23
12.2. Device Table.....	24



Manufactured for:
Aspar s.c.
ul. Oliwska 112
80-209 Chwaszczyno
POLAND

ampero@ampero.eu
www.ampero.eu

tel. +48 58 351 39 89; +48 58 732 71 73

