

Hydro-Probe / Hydro-Probe XT Installation Guide

To re-order quote part number:	HD0675
Revision:	1.4.0
Revision date:	Nov 2017

Copyright

Neither the whole or any part of the information contained in nor the product described in this documentation may be adapted or reproduced in any material form except with the prior written approval of Hydronix Limited, hereinafter referred to as Hydronix.

© 2017

Hydronix Limited
7 Riverside Business Centre
Walnut Tree Close
Guildford
Surrey GU1 4UG
United Kingdom

All rights reserved

CUSTOMER RESPONSIBILITY

The customer in applying the product described in this documentation accepts that the product is a programmable electronic system which is inherently complex and which may not be completely free of errors. In doing so the customer therefore undertakes responsibility to ensure that the product is properly installed commissioned operated and maintained by competent and suitably trained persons and in accordance with any instructions or safety precautions made available or good engineering practice and to thoroughly verify the use of the product in the particular application.

ERRORS IN DOCUMENTATION

The product described in this documentation is subject to continuous development and improvement. All information of a technical nature and particulars of the product and its use including the information and particulars contained in this documentation are given by Hydronix in good faith.

Hydronix welcomes comments and suggestions relating to the product and this documentation

ACKNOWLEDGEMENTS

Hydronix, Hydro-Probe, Hydro-Mix, Hydro-Skid, Hydro-View and Hydro-Control are Registered Trade Marks of Hydronix Limited

Hydronix Offices

UK Head Office

Address: 7 Riverside Business Centre
Walnut Tree Close
Guildford
Surrey
GU1 4UG

Tel: +44 1483 468900

Fax: +44 1483 468919

Email: support@hydronix.com
sales@hydronix.com

Website: www.hydronix.com

North American Office

Covers North and South America, US territories, Spain and Portugal

Address: 692 West Conway Road
Suite 24, Harbor Springs
MI 47940
USA

Tel: +1 888 887 4884 (Toll Free)

+1 231 439 5000

Fax: +1 888 887 4822 (Toll Free)

+1 231 439 5001

European Office

Covers Central Europe, Russia and South Africa

Tel: +49 2563 4858

Fax: +49 2563 5016

French Office

Tel: +33 652 04 89 04

Revision history

Revision No	Date	Description of Change
1.0.0	Feb 2015	First Release
1.1.0	May 2015	Cable product number changed
1.2.0	Jan 2016	Minor Formatting Update
1.3.0	March 2016	SIM02 reference added
1.3.1	July 2016	Accessories list updated
1.4.0	Nov 2017	Sensor model numbers updated

Table of Contents

Chapter 1 Hydro-Probe Installation.....	11
1 General to All Applications	12
2 Positioning the Sensor	13
3 Installing the Sensor.....	18
Chapter 2 Corrosion Protection.....	21
1 Corrosion Protection.....	21
Chapter 3 Technical Specification	23
1 Technical Specification.....	23
Appendix A Document Cross Reference	25
1 Document Cross Reference.....	25

Table of Figures

Figure 1: The Hydro-Probe Sensor	11
Figure 2: Hydro-Probe mounting angle and material flow	12
Figure 3: Fitting a Deflection Plate to prevent damage.....	12
Figure 4: Overhead View of Hydro-Probe Mounted in a Bin.....	13
Figure 5: Mounting the Hydro-Probe in the Neck of the Bin	13
Figure 6: Mounting the Hydro-Probe in the Bin Wall	14
Figure 7: Mounting the Hydro-Probe in Large Bins	14
Figure 8: Vibratory Feed Mounting	15
Figure 9: Mounting the Hydro-Probe on a Conveyor Belt.....	15
Figure 10: Hydro-Probe angled at 45° to reduce build-up	16
Figure 11: Mounting the Hydro-Probe in an En-Masse Conveyor	16
Figure 12: Mounting the Hydro-Probe in a Screw Conveyor	17
Figure 13: Hydro-Probe in Ducting	17
Figure 14: The Standard Mounting Sleeve (part no 0025)	18
Figure 15: The Extension Mounting Sleeve (part no 0026)	18
Figure 16: Flanged Mounting Sleeve (Part number 0024A)	19
Figure 17: Hydro-Probe installed under an Aggregate Bin.....	21
Figure 18: Hydro-Probe installed in an Extension Mounting Sleeve	21
Figure 19: Hydro-Probe installed with a Drip Loop	22
Figure 20: Hydro-Probe Protection Cover.....	22

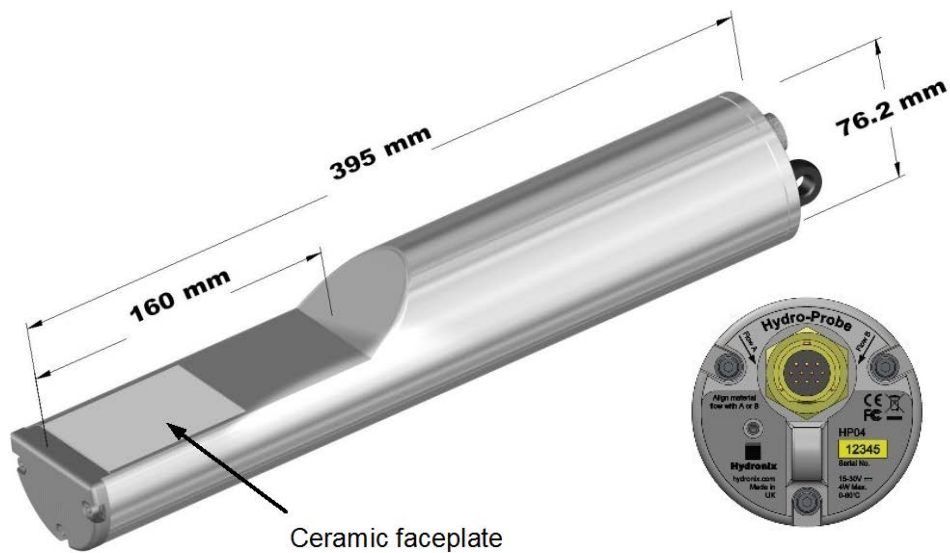

Figure 1: The Hydro-Probe Sensor

Available accessories:

0023	Clamp Ring
0025	Standard Mounting Sleeve
0026	Extension Mounting Sleeve
0024A	Flanged Mounting Sleeve (for vertical mounting)
0023	Clamp Ring for use with Flanged Mounting Sleeve
0975A	4m sensor cable
0975A-10m	10m sensor cable
0975A-25m	25m sensor cable
0116	Power Supply – 30 Watt for up to 4 sensors
0067	Terminal Box (IP56, 10 terminals)
0049A	RS232/485 converter (DIN rail mounting)
0049B	RS232/485 converter (9 pin D type to terminal block)
SIMxx	USB Sensor Interface Module including cables and power supply

Hydro-Com configuration and diagnostics software is available for free download from www.hydronix.com

This Hydro-Probe/Hydro-Probe XT Installation Guide is only valid for model numbers HP04 onwards and HPXT02 onwards. User guides for earlier Hydro-Probe model numbers are available from www.hydronix.com

1 General to All Applications

Follow the advice below for good sensor positioning:

- The 'sensing area' of the sensor (ceramic faceplate) should always be positioned in the moving, smooth, stream of material.
- The sensor should not obstruct the material flow.
- Position the sensor so that it is easily accessible for routine maintenance.
- To prevent damage from excessive vibration, position the sensor as far as reasonably practical from vibrators.
- To reduce material sticking to the sensor it should be angled with the ceramic faceplate initially set to 60° to the flow (as shown below). This is indicated on the label when the A or B line is in line with the material flow.
- It is recommended to install a switch close to the sampling point to manually start sensor averaging for calibration purposes. (see Electrical Installation Guide HD0678 for connection details)
- A calibration sample point must be available as close to the sensor as possible (no more than 150mm downstream)

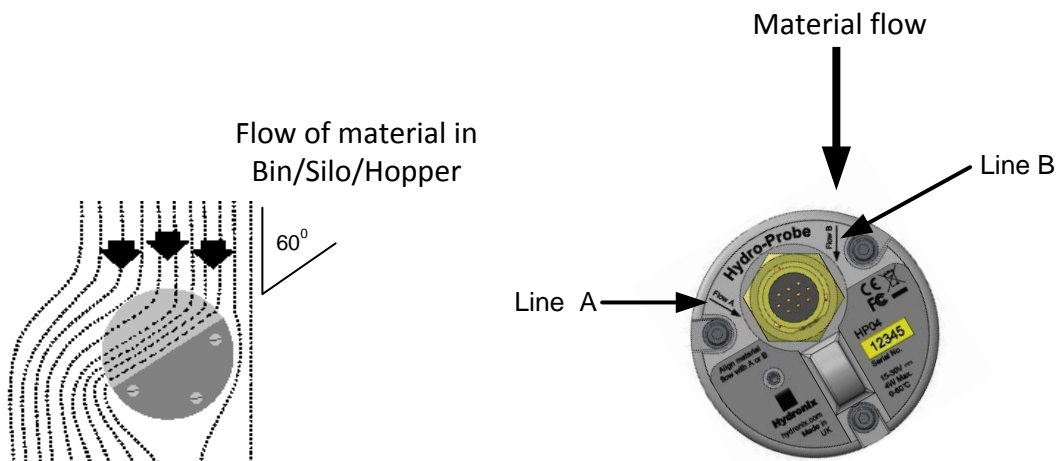

Figure 2: Hydro-Probe mounting angle and material flow

When filling a bin/silo/hopper using large aggregates (>12mm), the ceramic faceplate is susceptible to damage by direct or indirect impact. To prevent this, a deflection plate should be fitted above the sensor.

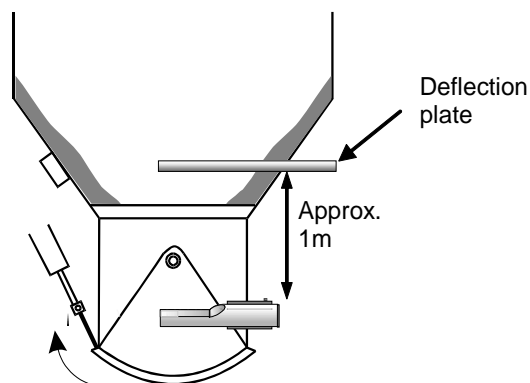

Figure 3: Fitting a Deflection Plate to prevent damage

2 Positioning the Sensor

The optimum location for the sensor varies depending on the type of installation – a number of options are detailed on the following pages. Several different mounting assemblies can be used to fix the sensor as shown on page 18.

2.1 Bin/Silo/Hopper Mounting

The sensor may be mounted in the neck or the wall of the bin so the ceramic faceplate is in the centre of the flow, as shown below.

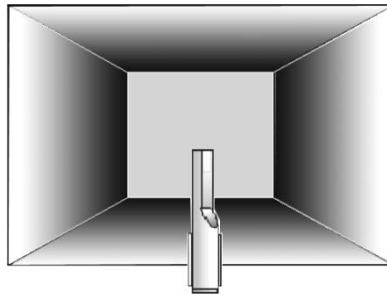

Figure 4: Overhead View of Hydro-Probe Mounted in a Bin

2.2 Neck Mounting

The sensor should be located on the opposite side to the door-opening and centred within the neck. If it is fitted on the same side as the ram, it should be angled towards the centre. Positioning the sensor under the bin will also help where space is limited.

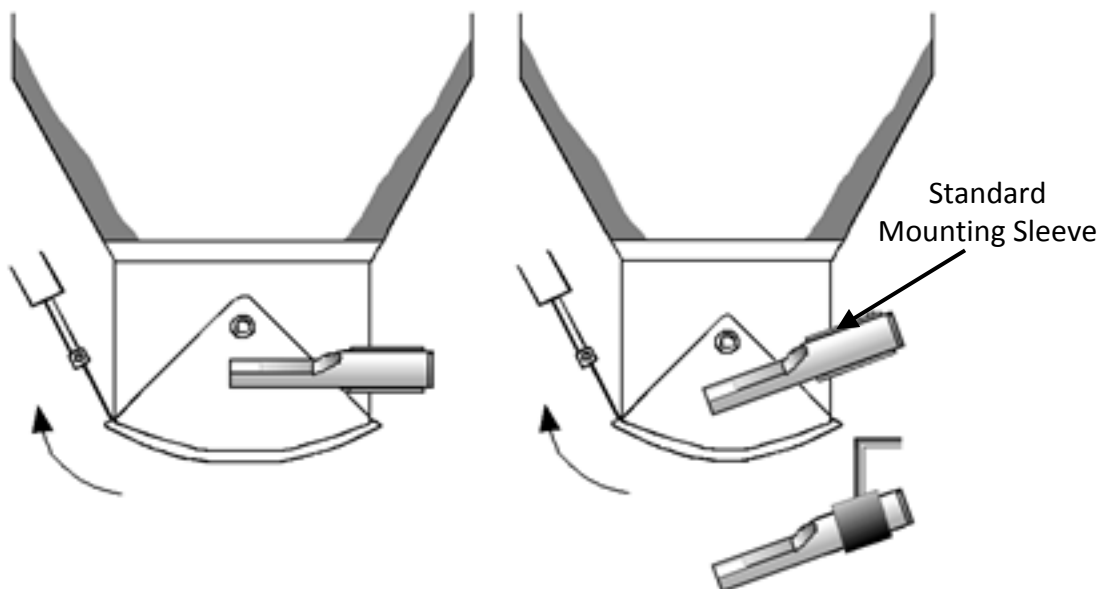

Figure 5: Mounting the Hydro-Probe in the Neck of the Bin

2.3 Bin Wall Mounting

The sensor can be placed horizontally in the bin wall, or if the space is limited, angled down to 45° as shown, using the Standard Mounting Sleeve (part no: 0025).

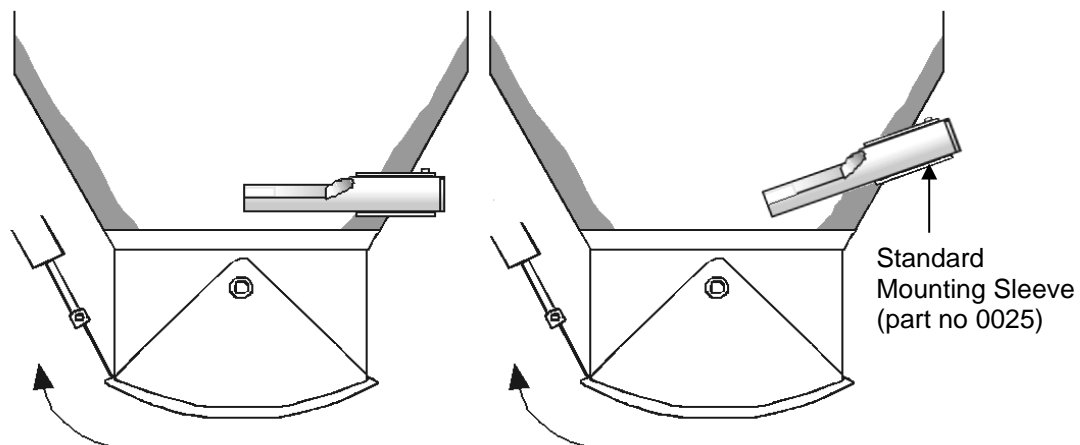

Figure 6: Mounting the Hydro-Probe in the Bin Wall

If the sensor does not reach the main flow of material, then an Extension Mounting Sleeve (part no 0026) should be used, as shown below.

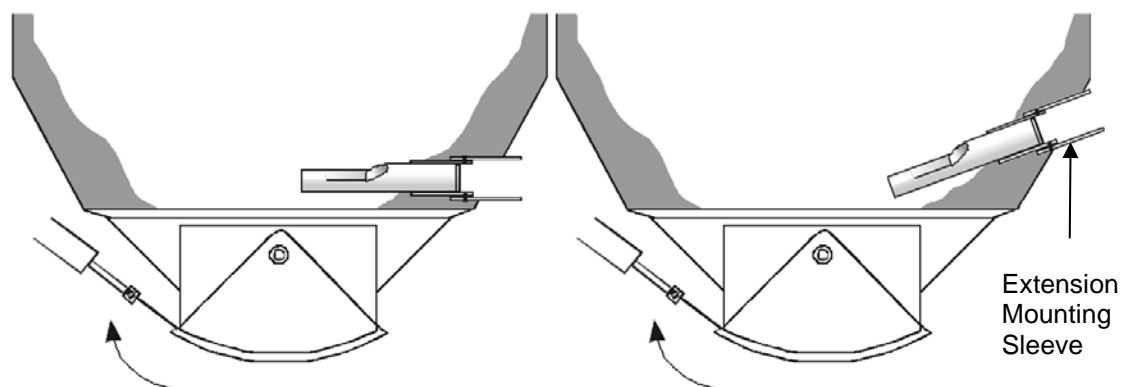

Figure 7: Mounting the Hydro-Probe in Large Bins

2.4 Vibratory Feed Mounting

With vibratory feeders, the sensor is normally fitted by the manufacturer – contact Hydronix for further information on positioning. It is difficult to predict where the flow of material occurs, but the location shown below is recommended.

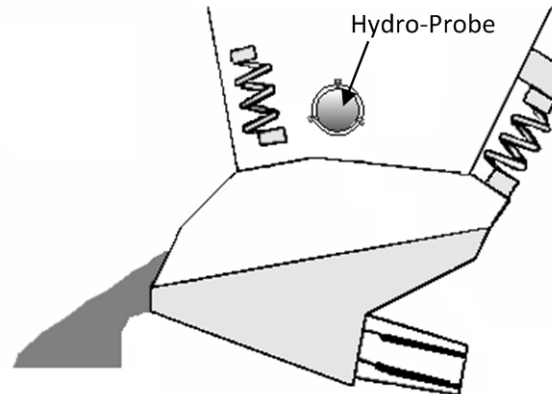

Figure 8: Vibratory Feed Mounting

2.5 Conveyor Belt Mounting

The sensor should be secured to a suitable fixing bar using a Flanged Mounting Sleeve (0024A) and a Clamp Ring (0023).

- Allow a 25mm gap between the sensor and the conveyor belt with a minimum of 150mm of material depth.
- Angle the sensor ceramic at 45° to the flow of material.
- To maintain consistent material depth diverters can be added to the belt (see below).

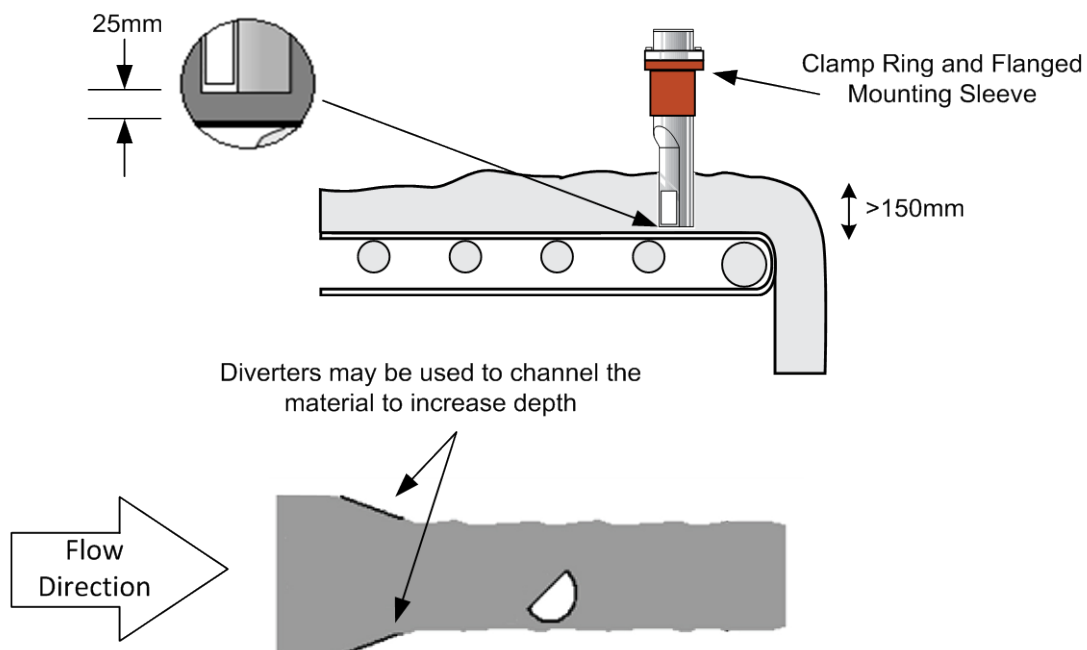

Figure 9: Mounting the Hydro-Probe on a Conveyor Belt

- The Hydro-Probe body can be installed at an angle of between 90° and 60° to the conveyor belt to reduce build-up of material. It is important to maintain the 45° angle to the material flow and the 25mm gap to the conveyor belt see Figure 10.

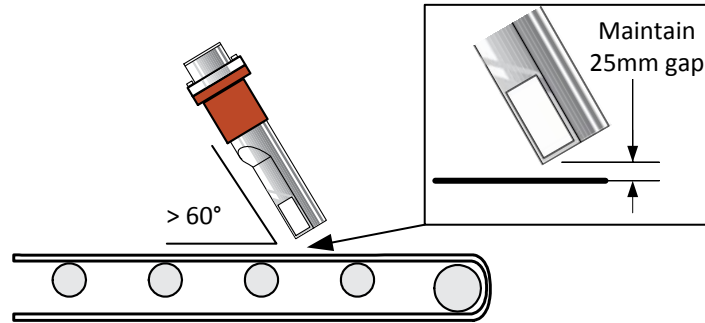

Figure 10: Hydro-Probe angled at 45° to reduce build-up

2.6 En-Masse (Chain) Conveyor Mounting

The sensor should be mounted using a Standard Mounting Sleeve in the side wall of the conveyor.

- The main body of the sensor should be mounted at an angle of 60° to the flow.
- The probe should be positioned close to the bottom of the conveyor so as much material as possible can pass over the ceramic faceplate.
- The probe should be inserted so that the centre of the ceramic is in the centre of the flow.
- The ceramic faceplate should be completely covered by a minimum of 100mm depth of material.

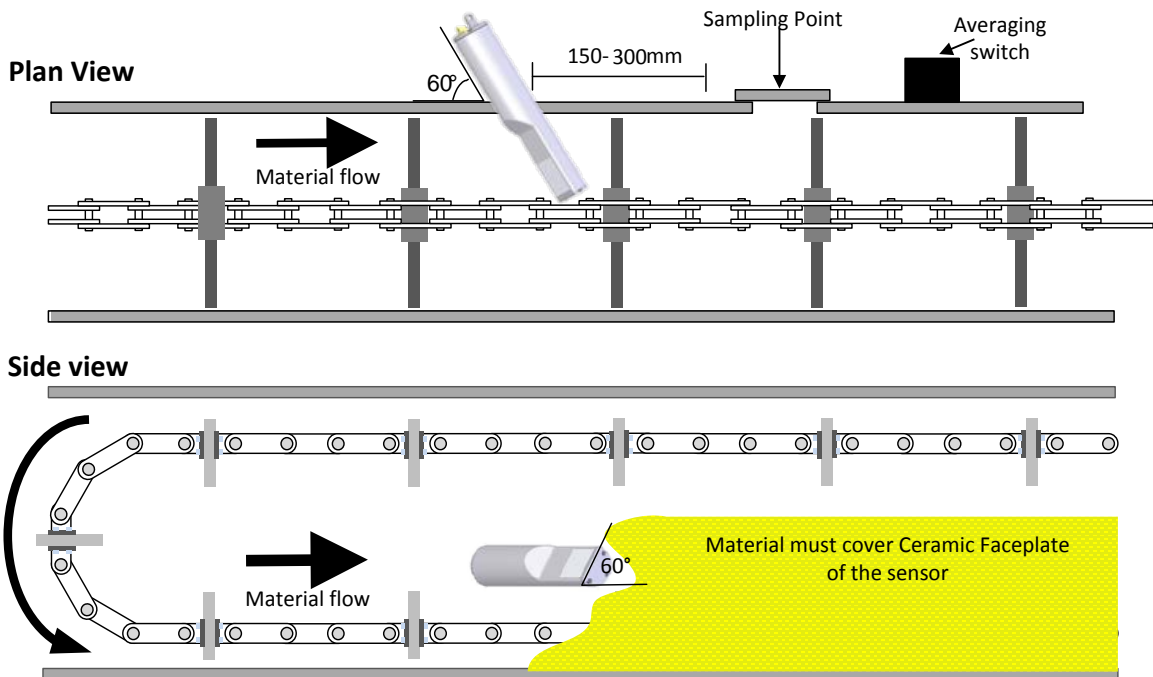

Figure 11: Mounting the Hydro-Probe in an En-Masse Conveyor

2.7 Screw Conveyor Mounting

The sensor should be mounted either at the flight-less end of the conveyor or, if this is not possible, the last section of the flight should be removed. The sensor should be mounted using a Standard Mounting Sleeve in the side wall of the conveyor.

- The main body of the sensor should be mounted at an angle of 60° to the flow.
- The probe should be positioned close to the bottom of the conveyor so as much material as possible can pass over the ceramic faceplate.
- The ceramic faceplate should be in the centre of the flow and completely covered by a minimum of 100mm depth of material.

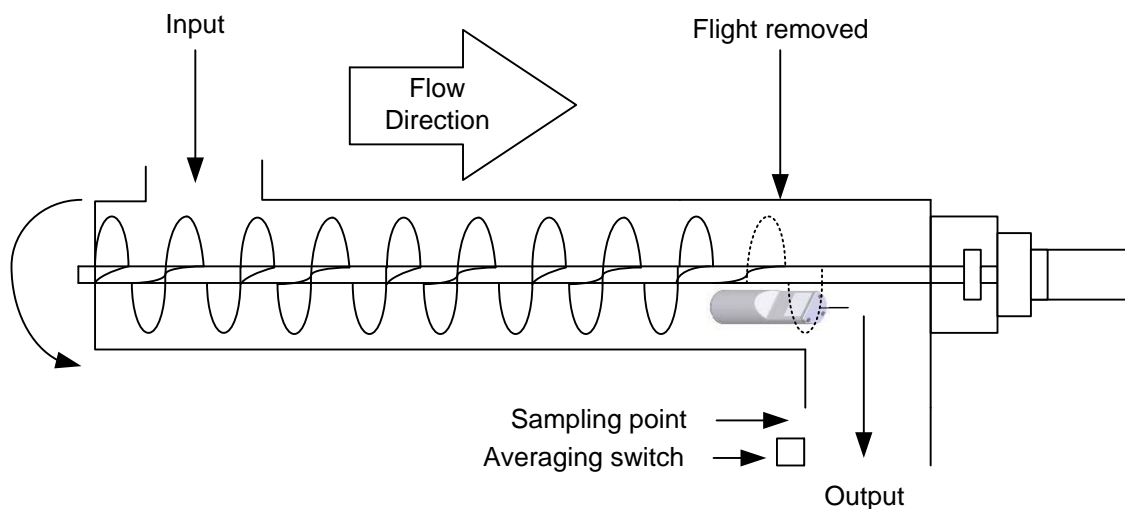

Figure 12: Mounting the Hydro-Probe in a Screw Conveyor

2.8 Installing in Ducting

To achieve reliable and consistent results in ducting the Hydro-Probe requires:

- Consistent, smooth flow rate.
- The sensor face is at 60° from the material flow

For further information on achieving consistent results in ducting see document EN0078.

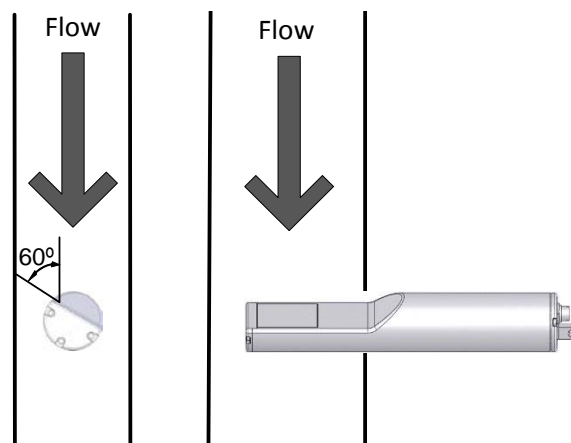

Figure 13: Hydro-Probe in Ducting

3 Installing the Sensor

There are three mounting accessories available from Hydronix.

3.1 Standard Mounting Sleeve (part no 0025)

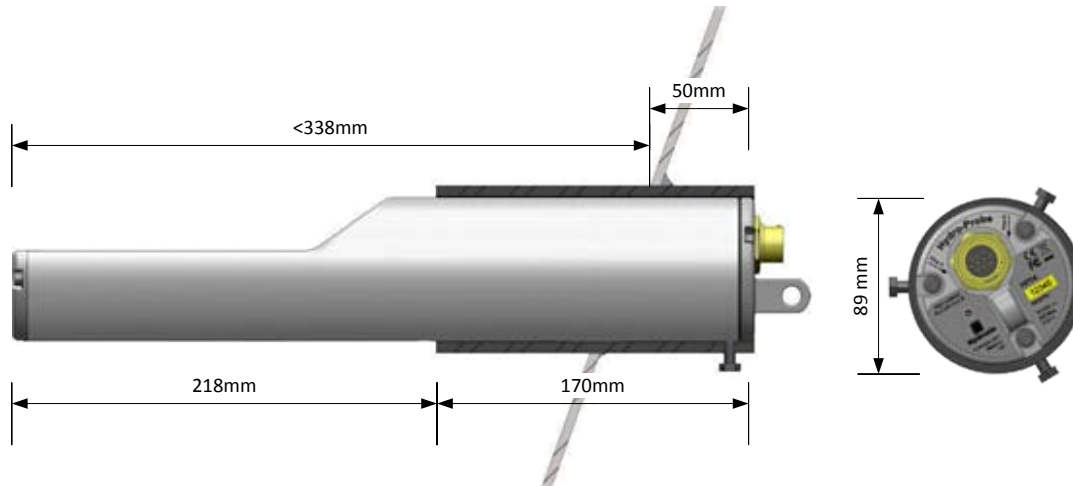
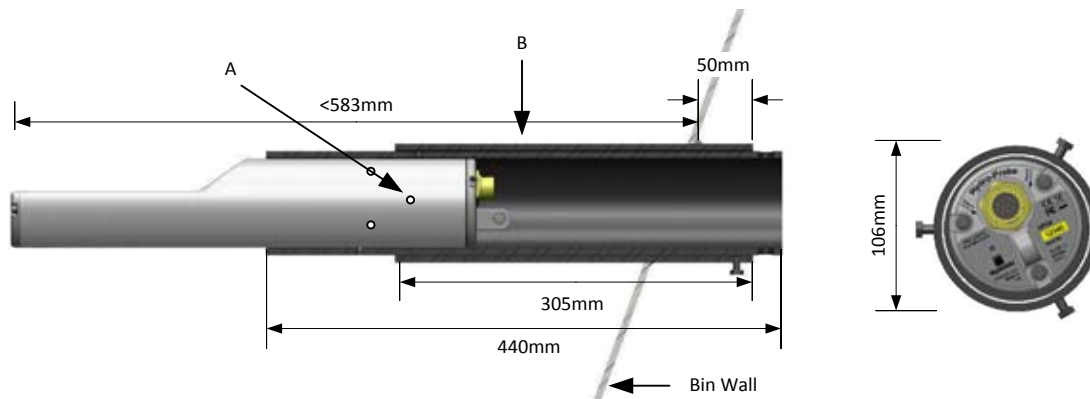

Figure 14: The Standard Mounting Sleeve (part no 0025)

3.2 Extension Mounting Sleeve (part no 0026)

For installation in larger bins



A – Sensor is secured to the inner sleeve by 6 hex screws (use Loctite or similar) on screw threads

B – Outer sleeve welded to bin

Figure 15: The Extension Mounting Sleeve (part no 0026)

3.3 Flanged Mounting Sleeve (part no 0024A)

For installations where vertical mounting is required, use with the Hydronix Clamp Ring, (part number 0023). A 100mm diameter hole is required to insert the Flanged Mounting Sleeve.

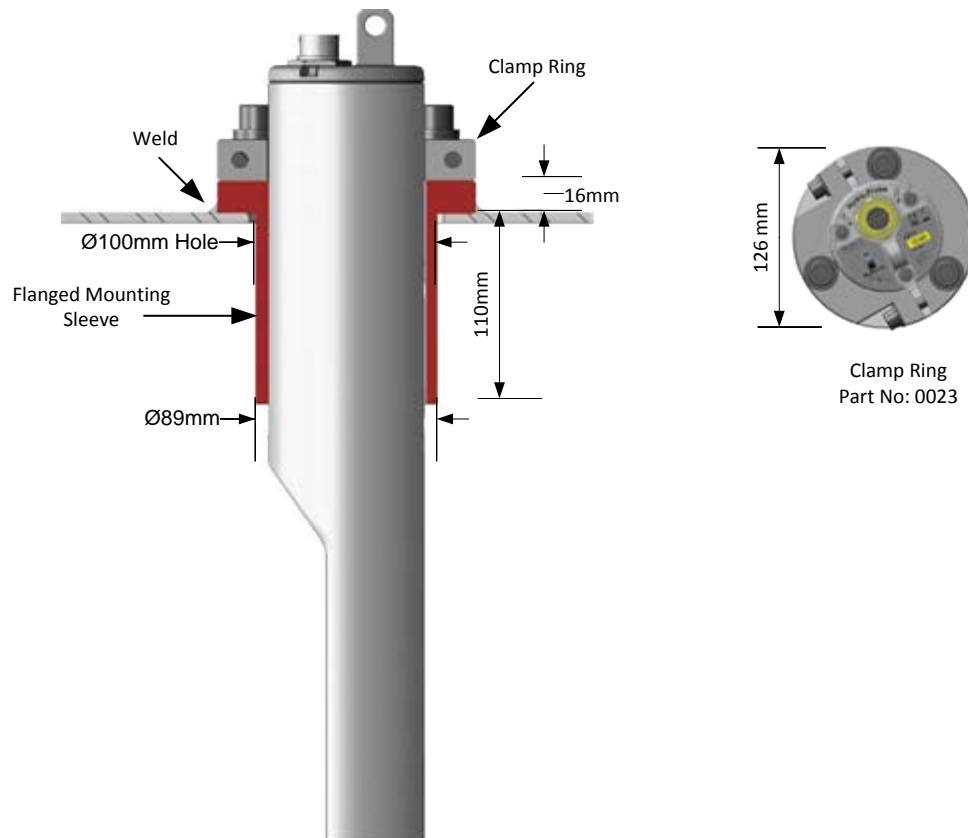

Figure 16: Flanged Mounting Sleeve (Part number 0024A)

1 Corrosion Protection

In situations where corrosive materials are in use, there is potential for the cable connector to be damaged. Protection from this corrosion is possible with a few simple adjustments to how the sensor is installed.

1.1 Sensor Position

Position the sensor so that no material comes into contact with the connector (See Figure 17).

The sensor must remain in the main flow of the material at all times to produce accurate measurements of the moisture.

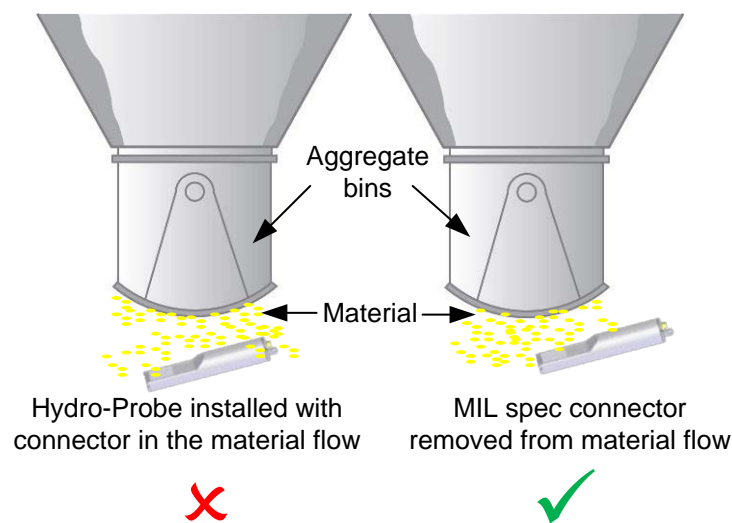

Figure 17: Hydro-Probe installed under an Aggregate Bin

1.1.1 Extension Mounting Sleeve

Installing the sensor using the Extension Mounting Sleeve (Part number 0026) will protect the connector from falling material. (See Figure 18).

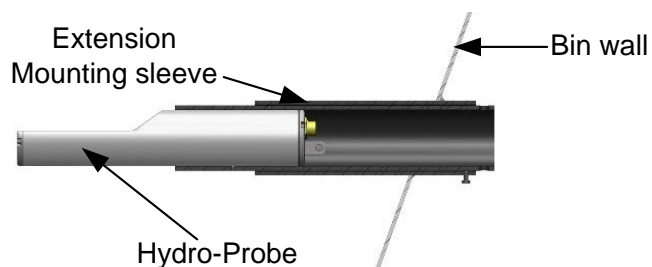

Figure 18: Hydro-Probe installed in an Extension Mounting Sleeve

1.1.2 Drip Loop

Although the connector is specified to withstand water ingress it is recommended to install with a drip loop in the cable. (See Figure 19).

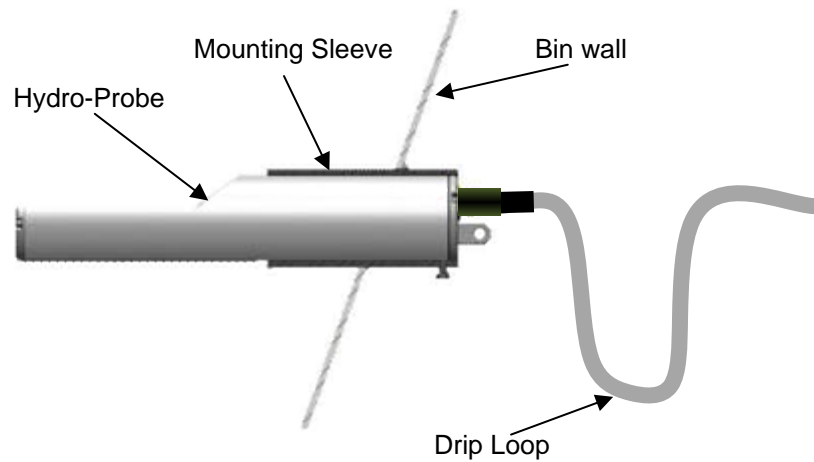

Figure 19: Hydro-Probe installed with a Drip Loop

1.1.3 Protection Cover

Install a cover over the top of the sensor to deflect the material away from the connector. (See Figure 20). Self-amalgamating tape can also be used to seal the connector.

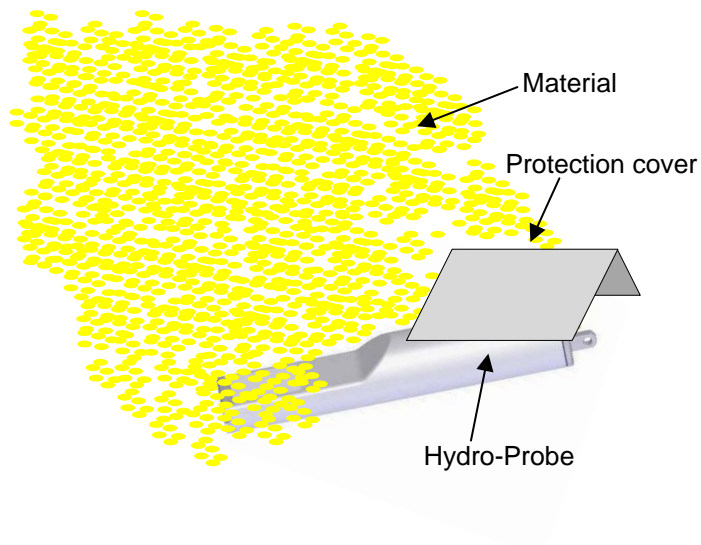

Figure 20: Hydro-Probe Protection Cover

1 Technical Specification

1.1 Dimensions

Diameter: 76.2mm

Length: 395mm

1.2 Construction

Body: Cast stainless steel

Faceplate: Ceramic

1.3 Penetration of Field

Approximately 75 -100mm dependent upon material

1.4 Range of Moisture

For bulk materials the sensor will measure up to the point of saturation.

1.5 Operating Temperature Range

0-60°C (32-140°F).The sensor will not measure in frozen material

1.6 Power Supply Voltage

15 - 30 VDC. 1 A minimum required for start-up (normal operating power is 4W).

1.7 Analogue Output

Two configurable 0–20mA or 4-20mA current loop outputs (sink) available for moisture and temperature. The sensor outputs may also be converted to 0-10Vdc

1.8 Measurement Modes

1.8.1 Hydro-Probe

Mode F only

1.8.2 Hydro-Probe XT

Mode F, Mode E, Mode V

1.9 Brix measurement output

No

1.10 Digital (Serial) Communications

Opto-isolated RS485 2 wire port – for serial communications including changing operating parameters and sensor diagnostics.

1.11 Digital Inputs

- One configurable digital input 15-30 V dc activation
- One configurable digital input/output – input specification 15 – 30 Vdc, output specification: open collector output, maximum current 500mA (over current protection required)

1.12 Connections

1.12.1 Sensor Cable

- Six pairs twisted (12 cores total) screened (shielded) cable with 22 AWG, 0.35mm² conductors.
- Screen (shield): Braid with 65% minimum coverage plus aluminium/polyester foil.
- Recommended cable types: Belden 8306, Alpha 6373
- 500 Ohm resistor – The recommended resistor is an epoxy sealed precision resistor of the following specification: 500 Ohm, 0.1% 0.33W)
- Maximum cable run: 100m, separate to any heavy equipment power cables.

1.13 Grounding

The sensor body is connected to the cable shield. Ensure equipotential bonding of all exposed metalwork. In areas of high lightning risk, correct and adequate protection should be used.

The sensor cable shield is connected to the sensor body. To prevent earth loops the shield must not be connected at the control panel.

1 Document Cross Reference

This section lists all of the other documents that are referred to in this User Guide. You may find it beneficial to have a copy available when reading this guide.

Document Number	Title
HD0678	Hydronix Moisture Sensor Electrical Installation Guide
EN0078	Integrating Hydro-Mix and Hydro-Probe sensors in ducting
HD0679	Hydronix Moisture Sensor Configuration and Calibration Guide

Index

Installation		Extension Mounting Sleeve	18
Advice	12	Flanged Mounting Sleeve	19
Corrosion protection	21	General	13
Deflection Plate	12	In Bin Wall	14
Position	12, 13	In Neck of Bin	13
Mounting		Options	18
Conveyor Belt	15	Vibratory Feeders	15