

VM7000A

PAPERLESS RECORDER

OUTLINE

This is a paperless recorder that displays measured data on the LCD in real time and stores data in SD memory card.

The type of input such as thermocouple, resistance bulb, DC voltage (current), etc. can be arbitrarily set to 12 channels at the maximum.

The data stored in SD memory card can be regenerated on the screen, and the use of supplied support software allows the data to be regenerated on a PC screen.

The data recorded in CSV format can be directly read in a spreadsheet such as Excel, which facilitates the processing on a PC. (the data recorded in binary format cannot be read in.)



FEATURES

- Easy operation with touch panel
It is possible to use it easily by an intuitive operation on which the touch panel depends.
- Large capacity storage by SD memory card
Measured data is periodically stored in SD memory card. In case of 2GB for example, display files for about 1.9 years. (in case of binary data format, 6 channels, maximum/minimum recording)
- Quick search and display of past data
Data stored in SD memory card can be displayed in succession by scrolling then screen.
- Various display capability
Depending on the object of measurement, the most suitable display format can be selected from a variety of formats including bar graph display, trend display, digital display, etc.
- PC support software supplied as standard
Parameter loader software that enables easy display and change of set data and data viewer software that regenerates the data stored in SD memory card are supplied as standard.
- Compact size and Lightness
150(W)×144(H)×208(D)mm (The terminal stand cover is contained.)
Lightness About 1.0kg (6 channels input, without option)
- 12 points recording
12 types of thermocouples, 4 types of resistance bulbs and DC voltage/current input can be recorded up to 12.
- LCD extinguishing function
Automatically extinguishes the LCD if nothing is operated for certain time. You can set the time after a lapse of which the LCD is extinguished via parameter "LCD extinguishing time". The settable range is 0 to 60 minutes.
This function prevents the backlight life from shortening uselessly. During the extinguishment, the power consumption can be reduced.
- Ethernet function
FTP, Web server, SNTP and Modbus TCP function are available. (10Base-T)
- Communication (Option)
RS-485 Modbus communication is available.

SPECIFICATIONS

- Number of input points :
3, 6, 9 or 12 points (can be selected at the time of purchase)
- Input circuit :
Input mutual isolation.
- Measuring cycle :
100ms
- Input types :
DC Voltage, DC current (Shunt resistor are fitted in input terminals), thermocouple, resistance bulb.
- Selection of input types :
In the key operation with a set screen.
- Burn out function :
Provided as standard for thermocouple and resistance bulb inputs.
When the input is disconnected, the record is shaken off on 100% side.
- CMRR : 140dB or more
- NMRR : 60dB or more
- Allowable signal source resistance :
It is the effect of about 0.18 micro/ Ω at the time of those with a burnout.
5 Ω or less of lead wire resistance of a resistance bulb
- Input filter function :
Settable for each channel. (first order lag filter)
Time constant settable in the range from 0 to 99 second.
- Scaling function :
Possible by DC voltage (current) input.
Scaling range : -32000 to +32000
Decimal position settable at any point
The unit symbol settable from 12 units (each unit eight characters or less) that can be made from among the unit that is the preset.
- Extraction-of-square-root calculation function :
Extraction-of-square-root (root) operation is performed to the input value of each channel.
- Calculation function :
Calculation channels : 36 points
Arithmetic operation, general operation, and

addition operation and F value operation are possible by each operation channel.

F value calculation function :

An F value (fatality value of the bacillus by heat pasteurization) is calculated from measurement temperature for every channel.

Arithmetic contents can be set up only with parameter loader software (par attached PC software).

MEASUREMENT RANGE

From the input setting screen displayed to push the front MENU key (hard key), it can set up arbitrarily for every channel.

Code	Type	Measuring range	Max. resolution	Measurement accuracy	notes
000	mV	-10.00 ~ +10.00	10 μ V	$\pm (0.1\%+1 \text{ digit})$	
001	mV	0.00 ~ +20.00	10 μ V		
002	mV	0.00 ~ +50.00	10 μ V		
003	V	-0.200 ~ +0.200	1mV		
004	V	-1.000 ~ +1.000	1mV		
005	V	-10.00 ~ +10.00	10mV		
006	V	0.000 ~ +5.000	1mV		
007	mA	4.00 ~ 20.00	0.01mA	$\pm (0.1\%+1 \text{ digit})$	*1 0~400°C: $\pm 4\%$ *2 0~200°C: $\pm (0.15\%+1 \text{ digit})$
008	B *1	0.0 ~ 1820.0	0.1°C		
009	R1 *2	0.0 ~ 1760.0	0.1°C		
010	R2 *2	0.0 ~ 1200.0	0.1°C		
011	S *2	0.0 ~ 1760.0	0.1°C		
012	K1	-200.0 ~ 1370.0	0.1°C		
013	K2	-200.0 ~ 600.0	0.1°C		
014	K3	-200.0 ~ 300.0	0.1°C		
015	E1	-200.0 ~ 800.0	0.1°C		
016	E2	-200.0 ~ 300.0	0.1°C		
017	E3	-200.0 ~ 150.0	0.1°C		
018	J1	-200.0 ~ 1100.0	0.1°C		
019	J2	-200.0 ~ 400.0	0.1°C		
020	J3	-200.0 ~ 200.0	0.1°C		
021	T1	-200.0 ~ 400.0	0.1°C		
022	T2	-200.0 ~ 200.0	0.1°C		
023	C	0.0 ~ 2320.0	0.1°C		
024	Au-Fe *3	1.0 ~ 300.0	0.1K	$\pm (0.2\%+1 \text{ digit})$	*3 1~20K: $\pm (0.5\%+1 \text{ digit})$ 20~50K: $\pm (0.3\%+1 \text{ digit})$
025	N	0.0 ~ 1300.0	0.1°C	$\pm (0.1\%+1 \text{ digit})$ However, -200.0 to 0.0°C is $\pm (0.15\%+1 \text{ digit})$	
026	PR40-20 *4	0.0 ~ 1880.0	0.1°C	$\pm (0.2\%+1 \text{ digit})$	*4 0~300°C: $\pm (1.5\%+1 \text{ digit})$ 300~800°C: $\pm (0.8\%+1 \text{ digit})$
027	PL II	0.0 ~ 1390.0	0.1°C	$\pm (0.1\%+1 \text{ digit})$	
028	U	-200.0 ~ 400.0	0.1°C	However, -200.0 to 0.0°C is $\pm (0.15\%+1 \text{ digit})$	
029	L	-200.0 ~ 900.0	0.1°C	$\pm (0.15\%+1 \text{ digit})$	$\pm (0.1\%+1 \text{ digit})$
030	Pt100-1	-200.0 ~ 650.0	0.1°C		
031	Pt100-2	-200.0 ~ 200.0	0.1°C		
032	JPt100-1	-200.0 ~ 630.0	0.1°C		
033	JPt100-2	-200.0 ~ 200.0	0.1°C		

[Caution] Accuracy on basis conditions. Reference junction compensation accuracy is not included in digital display accuracy.

- Reference junction compensation accuracy :
 R,S,B,PR4020,Au-Fe : $\pm 1^\circ\text{C}$
 K,E,J,T,C,N,PL II ,U,L : $\pm 0.5^\circ\text{C}$

• Basis conditions :

Ambient temperature : $23\pm 2^\circ\text{C}$
 Ambient humidity : $55\pm 10\% \text{RH}$
 Supply voltage : 85 to 264V AC
 Power supply frequency : $50/60 \text{Hz} \pm 1\%$
 Warmup time : It is 30 minutes or more from a power up.

DISPLAY

- Display unit :
5.7-inch TFT color LCD (320×240 pixels)
The contrast can be adjusted.
(notes)
The pixel might exist though the liquid crystal display always lights partially or doesn't light.
Moreover, please acknowledge it to be no breakdown beforehand though irregularity might be caused in brightness though the characteristic of the liquid crystal.
- Display Color :
Selectable from 16 colors
- Display language :
Japanese/English can be chosen from the screen which sets up.
- Back light life
50,000 hours
- Display group :
Group number : Main record 6, Sub record 1
Channel number: A maximum of each 12 groups' display setting is possible.
- Real-time trend display :
The present measurement data is displayed in a chart.
Direction : The upper and lower sides or right and left
A digital readout/non-display one, a scale display / non-display choice is possible.
Display renewal period 1 second
- Historical-trend display :
The past measurement data is displayed in a chart.
Direction : The upper and lower sides or right and left
A digital readout/non-display one, a scale display / non-display choice is possible.
- Bar graph display :
The present measurement data is displayed by a lengthwise direction bar graph.
Display renewal period 1 second
- Digital display :
It is an enlarged display about the present measurement data (value).
Alarm occurrence No. is displayed.
Display renewal period 1 second
- Event history :
An alarm history, comment data, and a self-diagnostics report are displayed.
- Communication hysteresis :
Communication hysteresis is displayed.
- Parametric representation/setting out :
An information set screen is displayed with a front MENU key.
- Tag display :
The number of characters which can be displayed : A maximum of eight characters

MANUAL OPERATION BUTTON

- The number of keys :
Three pieces (it can be operated if the cover of the lower part of front is opened)
- Function :

REC. : start/stop of record

MENU : Various setting screens are displayed.

FUNC. : The function assigned beforehand is performed.

RECORDING FUNCTION

- External recording medium :
SD memory card (it corresponds to SD/SDHC specification)
- Internal memory : About 100MB
- Storage capacity :
SD specification : A maximum of 2GB
SDHC specification : A maximum of 32GB
- The record mode :
Record is started by turning on a REC. key.
It records by a new file name for every recording start.
- Main record :
It records about each channel data of main record 6 group who set up by display groups.
The contents of record are trend data, event data, and comment data.
- Sub record :
It records about each channel data of sub record 1 group who set up by display groups.
The contents recorded are only trend data.
As a recording condition, "it is made to synchronize with main record", "when an alarm occurs" either "when DI turns on" can be chosen.
- Data logging period :
1 second to 60 minutes to a choice of the period on which data are recorded is possible (the data logging period of 100ms can also be chosen only for sub record).
- File preservation period :
Record data are saved first at an internal memory, and if memory fills, they are written in SD memory card at the time of a record stop.
The data storage terminal of one recorder file can be chosen in the range for 1 hour to one year.
- Trend data :
The minimum of an average, an instantaneous value, or measured value or the maximum is saved out of the measurement data sampled with the measurement cycle.
- In addition, record data :
Alarm information, a message, comment record
- Preservation capacity :
the case of the following conditions -- the time record of the following table -- it can carry out.
[Conditions]
 - Number of inputs : 6 points
 - File preservation period : One day
 - Record data format : Binary
 - Record type : The maximum / minimum record
 - With no events, such as an alarm and a message

SD memory card Capacity	2GB				
Data logging period	1 second	2 seconds	5 seconds	10 seconds	1 minute
Record possible capacity	1.9 years	3.7 years	8.0 years	14.0 years	33.7 years

* The record exceeding a life cycle is not guaranteed.

- Memory activity capacity display :
The amount of an internal memory or SD memory card used is indicated by percent on the screen of this machine.
If the recording region of SD memory card is lost, setting out whether record is stopped or it deletes from old data and record continuation is carried out is possible.
- SD memory card :
The operation confirming finishing SD memory card is as follows (the action by SD memory card other than this becomes the outside for a guarantee).
* It is [response SD memory card] under checking now.
(It corresponds also to the memory card of SDHC specification).
Please purchase in a personal computer shop etc.
- Data format :
One mode of the binary or binary + CSV formats to a choice is possible.
(A change-over is impossible during record. A CSV format can be read directly at Excel etc. The data recorded in the binary format cannot be read.)
CSV format : About 120 bytes per one sampling (at the time of a six-channel input, and the maximum / the minimum record).
Binary format : about 30 bytes (at the time of a six-channel input, and the maximum / the minimum record)

ALARM FUNCTION

- Set number :
A maximum of four points can be set as each channel.
- Type of alarm :
High and low limits, abnormal data
- Display :
It displays on a digital display screen at the time of an alarm occurrence.
It displays on the right limit of an up-and-down trend display screen, and the drag flask of a right-and-left trend chart in red.
- Hysteresis :
Setting out is possible in 0 to 100% of a range.
- Alarm output :
Common alarm output :
One point (open collector output)
Contact rating : 30V DC 20mA/1 point

POWER SUPPLY

- Rated supply voltage :

- 100 to 240V AC
- Working voltage range :
85 to 264V AC
- Power supply frequency :
50/60Hz (common use)
- Power consumption :

Supply voltage	Consumption	
	Normal	LCD off
AC100V	15VA or less	12VA or less
AC240V	25VA or less	22VA or less

STRUCTURE

- Mounting method :
Panel embedding anchoring (vertical panel)
- Mounting posture :
Zero to 30 back, right-and-left horizontal
- Anchoring panel thickness : 2 to 7 mm
- Construction material : Polycarbonate
- Color : Black
- Dimension : 150(W) x 144(H) x 208 (D) mm
- Mass : About 1.0kg (6 channels)
- External terminal block : M3.5 screw-thread terminal

NORMAL OPERATING CONDITION

- Supply voltage : 85 to 264V AC
- Ambient temperature : 0 to 50 °C
- Ambient humidity : 20 to 80%RH
- Warmup time : It is 30 minutes or more from a power up.

OTHERS

- Clock :
Accuracy Less than ± 50 ppm (monthly difference about 2 minutes)
However, the error at the time of power-source ON/OFF is not included.
- Memory backup :
A parameter is saved at an internal flash memory.
A clock is backed up with a built-in lithium cell (battery life about five years at the time of no turning on electricity).
- Insulation resistance :
20Mohm (500V DC during each terminal-earth)
- Withstand voltage :
Between input terminals -- For [500V AC] 1 minute
During power supply terminal-earth -- For [2000V AC] 1 minute
During input terminal-earth -- For [500V AC] 1 minute

ADAPTATION SPECIFICATION

- CE :
EMC directive: 61326 to EN1 adaptation
Low Voltage Directive: 61010 to EN1 adaptation
- Protection-against-dust / water proof specification :
JIS C0920 IP65 (front panel) Conformity

TRANSPORTATION / STORAGE CONDITIONS

- Temperature : -10 to 60 °C
- Humidity : 5 to 90 %RH

- Oscillation : It is below 2.45 m/s² 10to60Hz.
- impact : Below 249 m/s² (packed state)

ADDITIONAL FUNCTION (OPTION)

■ Communication

Mounting of RS-485 communication module is possible.
(the 8th figure of formal code "1")

• Communication function :

Electrical specifications : EIA RS-485 conformity
Protocol: Modbus RTU

The communication mode : two-wire-system
half-duplex: Start-stop

The data format : data length: 8 bits

Stop bit: 1 bit

parity : -- even number and odd number --
nothing

Transmission speed : 9600

The number of Maximum connection: 32 master
(Multidrop)

Communication range : A maximum of 500m
(total extension)

■ DI/DO card (the 9th figure of formal code "1")

One installation is possible in a card with DI input of nine points, and DO output of 12 points.

However, if the number of inputs is 12 points, it cannot be mounted at the time of a relay output card choice.

- Connection type : Connector (40 pins, DI/DO mixture)
- Insulation resistance : More than 500V DC 20Mohm (between each terminal-G terminal)
- Withstand voltage : 500V DC 10mA 1minute (between each terminal-G terminal)
- DI input :

a no voltage contact input (nine points)

Rating : Photo-coupler actuation 12V DC about
3mA/1 point

The next control is possible by a contact input
(500ms or more of ON/OFF pulse periods).

(1) The main, and initiation/halt of a sub record
action

(2) Comment setting out

(3) Integrated value reset

(4) LCD backlight ON/OFF control

• DO output :

open collector output (12 points)

Contact rating : 30V DC 20mA/1 point

Assignment is possible as an alarm output.

■ Relay output card (the 9th figure of formal code "2")

One installation is possible in a card with the relay output of 6 points.

However, if the number of inputs is 12 points, it cannot be mounted at the time of a DI/DO card choice.

Assignment is possible as an alarm output.

- Connection type : Terminal Block (M3.5 screw)
- Contact capacity : 3A/250VAC, 3A/30V DC
however, 3A / 1 common and a total -- the thing
below 9A.
- Insulated mode : Photo-coupler insulation
- Insulation resistance :
More than 500VDC 20Mohm (between
relay-terminals-FG)

- Withstand voltage :
500VDC 10mA 1min
(between relay-terminals-FG)

ETHERNET

■ HTTP server

• Measured-value display :

It is a digital value display about the measured
value and the alarm condition of each channel.

■ FTP server

• File download :

Download of the recorder file saved at SD
memory card is possible.

• File deletion :

Deletion of the recorder file saved at SD
memory card is possible.

• Access authentication :

The access privilege to an FTP server is
attested.

■ Modbus TCP

• Data read in :

The read in of setting out is possible at a
Modbus TCP protocol.

• Data write :

The writing of setting out is possible at a Modbus
TCP protocol.

■ SNTP

• SNTP client function :

It is possible to synchronize time with the time of
a SNTP server.

SUPPORT SOFTWARE

In two kinds of support software, it is par and attached.

- A response type is a PC/AT compatible machine.
- An action with a hand made PC or a shop brand personal
computer cannot be guaranteed.
- Disk unit :

The CD-ROM drive corresponding to Windows
XP/Vista

Capacity of hard disk drive :

500MB or more of the minimum availability

- OS : Windows XP/Vista

- Printer :

The printer and printer driver corresponding to
Windows XP

■ Parameter loader software

• The main functions :

It is the software for setting out and making a
change of the various parameters of a body on
a personal computer.

The description of setting out can be saved at
SD memory card, and can be made to read by
a recorder.

■ Data viewer software

The main functions :

It is the software which reproduces the record
data saved at SD memory card on a personal
computer.

A historical-trend display and an event display
are equipped.

Data can be outputted to a CSV file.

MODEL CODE NUMBER

1 2 3 4 5 6 7 8 9 10 11
 V M 7 0 A O O

digit	Specifications	code
5-6	<Number of input points >	
	03	03
	06	06
	09	09
	*12	12
8	<Communication option>	
	None	0
	RS-485	1
9	<Input/Output Option >	
	None	0
	DI/DO card	1
	Relay Output card	2

*If the 12 numbers of inputs are chosen, the DI/DO card and Relay Output card of an option cannot be chosen.

STANDARD ACCESSORY

Item		Quantity
Recorder		1
Panel mounting bracket		2
CD-ROM	PC support software Instruction manual (Japanese/English)	1
Panel packing for front water proof		1

(Note) SD memory card is not attached.

Please purchase in a personal computer shop etc.

OPTION ITEM

Item	Code
Shunt resistance for a direct-current input (250ohm±0.1%)	HMSU3081A11
The terminator for RS-485 (200Ω)	WMSU0303A01

Terminal Arrangement

If you have no option card (a DI/DO card, a relay output card)
 All terminals are M3.5 screws.

Power Supply Terminal

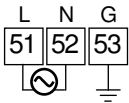

COM. ALM.



RS-485(option) Terminal



(SD/RD+) (SD/RD-)

(Note) In the case of an end station, please connect a terminator.

Input Terminals

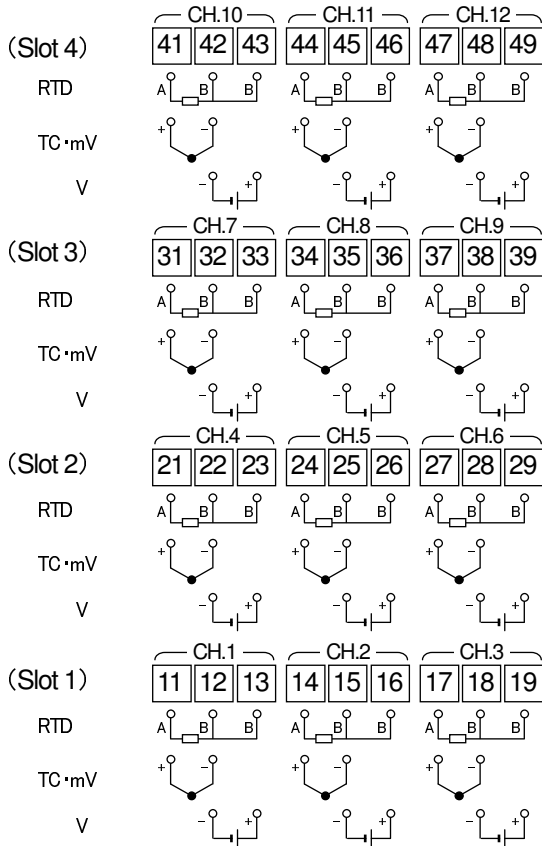

(Note) The terminal block of a channel without an input is not mounted by a model code.
 For example, in the case of the nine numbers of inputs, there is no Terminal Block of 41 to 49.

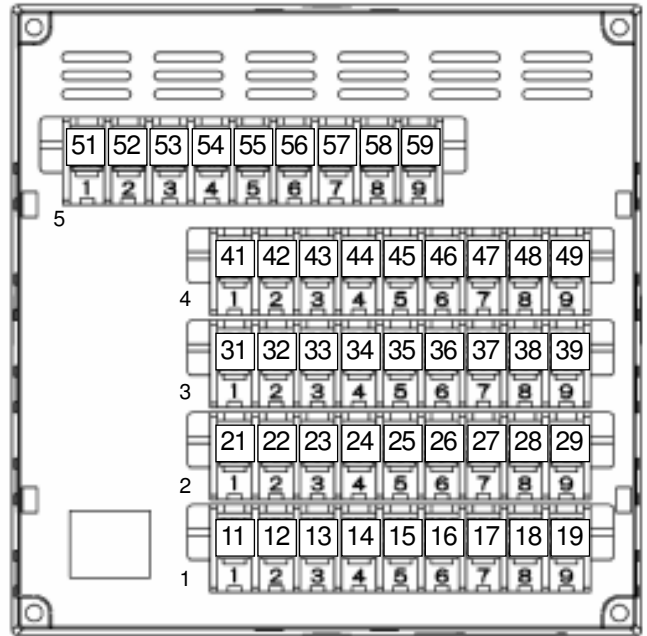

[Terminal block arrangement]

In the case of with a DI/DO card (option)

A slot 4 (Terminal Block part of the above figures 41 to 49) serves as a connector.

DI : A no voltage contact input (nine points)
 DO : Open collector output (12 points)



Pin No.	Signal	Pin No.	Signal
1	DI1	21	DO1
2	DI2	22	DO2
3	DI3	23	DO3
4	DI4	24	DO4
5	DI5	25	DO5
6	DI6	26	DO6
7	DI7	27	DO7
8	DI8	28	DO8
9	DI9	29	DO9
10	NC	30	DO10
11	NC	31	DO11
12	NC	32	DO12
13	DI_COM	33	DO_COM
14	DI_COM	34	DO_COM
15	DI_COM	35	DO_COM
16	DI_COM	36	DO_COM
17	DI_COM	37	DO_COM
18	DI_COM	38	DO_COM
19	DI_COM	39	DO_COM
20	DI_COM	40	DO_COM

In the case of with a relay output card (option)

All terminals are M3.5 screws.

Contact capacity :

3A/250VAC, 3A/30V DC
 however, 3A/1 comon a total -- thing below 9A.

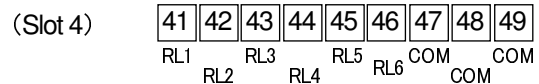

DIMENSIONS (Unit = mm)

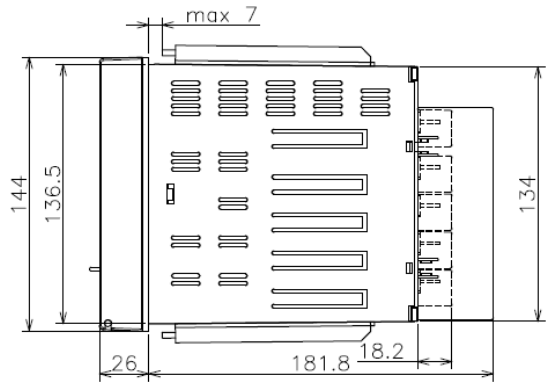
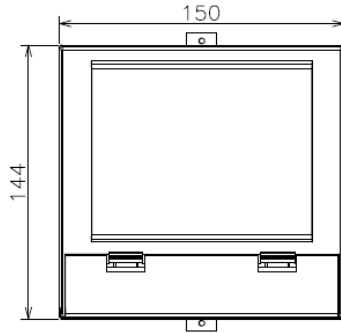
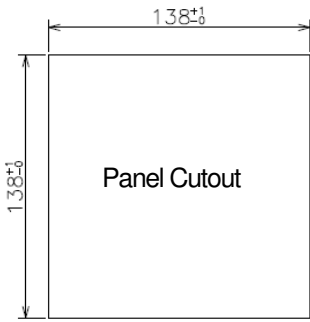

⚠ CAUTION

Do not install this device before consulting instruction manual

Ohkura

OHKURA ELECTRIC CO., LTD.

Head Office / Factory

Sales Offices

URL

e-mail (in English)

Saitama, JAPAN

Tokyo, Osaka, Nagoya, Kyushu, Tohoku

<http://www.ohkura.co.jp/>

intsales@ohkura.co.jp

Specifications are subject to change without notice.

For further information, a quotation or a demonstration please contact to:

