

SDM-8180

Expansion Module – 8 digital inputs, 8 digital outputs

Version 1.2 — 20.01.2014

User Manual



Manufactured for

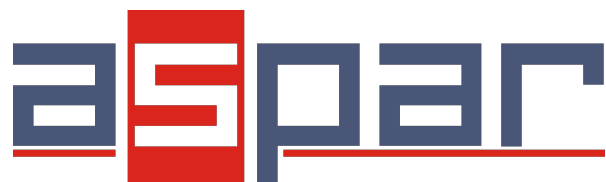

Thank you for choosing our product.

This manual will help you with proper support and proper operation of the device.

The information contained in this manual have been prepared with utmost care by our professionals and serve as a description of the product without incurring any liability for the purposes of commercial law.

This information does not release you from the obligation of own judgement and verification.

We reserve the right to change product specifications without notice.

Please read the instructions carefully and follow the recommendations contained therein.



WARNING!

Failure to follow instructions can result in equipment damage or impede the use of the hardware or software.

1. Safety rules

- Before first use, refer to this manual
- Before first use, make sure that all cables are connected properly
- Please ensure proper working conditions, according to the device specifications (eg: supply voltage, temperature, maximum power consumption)
- Before making any modifications to wiring connections, turn off the power supply

2. Module Features

2.1. *Purpose and description of the module*

The SDM-8I8O module is an innovative device that provides a simple and cost-effective extension of the number of lines of input and output in popular PLCs.

The module has 8 digital inputs with configurable timer/counter option and 8 digital outputs. In addition, terminals IN1 and IN2 and IN3 and IN4 can be used to connect two encoders. All inputs and outputs are isolated from the logic of using optocouplers. Each channel can be individually configured in one of several modes.

This module is connected to the RS485 bus with twisted-pair wire. Communication is via MODBUS RTU or MODBUS ASCII. The use of 32-bit ARM core processor provides fast processing and quick communication. The baud rate is configurable from 2400 to 115200.

The module is designed for mounting on a DIN rail in accordance with DIN EN 5002.

The module is equipped with a set of LEDs used to indicate the status of inputs and outputs useful for diagnostic purposes and helping to find errors.

Module configuration is done via USB by using a dedicated computer program. You can also change the parameters using the MODBUS protocol.

2.2. Technical Specifications

Power Supply	Voltage	10-30 VDC; 10-28VAC
	Maximum Current*	DC: 100 mA @ 24VDC AC: 125 mA @ 24VAC
	Maximum power consumption	DC: 2.4W; AC: 3VA
Digital Inputs	No of inputs	8
	Voltage range	0 – 36V
	Low State „0”	0 – 3V
	High State „1”	6 – 36V
	Input impedance	4kΩ
	Isolation	1500 Vrms
	Input Type	PNP lub NPN
Digital Outputs	No of outputs	8
	Max Voltage	30V
	Max current	500mA
	Output Type	PNP
	Output protection	4A polymer fuse
Isolation	1500 Vrms	
Counters	No	8
	Resolution	32 bity
	Frequency	1kHz (max)
	Impulse Width	500 μs (min)
Temperature	Work	-10 °C - +50°C
	Storage	-40 °C - +85°C
Connectors	Power Supply	2 pins
	Communication	3 pins
	Inputs	10 pins
	Outputs	10 pins
	Configuration	Mini USB
Size	Height	110 mm
	Length	62 mm
	Width	88 mm
Interface	RS485	Do 128 urządzeń

* Maximum current with active Modbus transmission, all outputs on and high state on all inputs

2.3. Dimensions of the product

Look and dimensions of the module are shown below. The module is mounted directly to the rail in the DIN industry standard. Power connectors, communication and IOs are at the bottom and top of the module. USB connector configuration and indicators located on the front of the module.

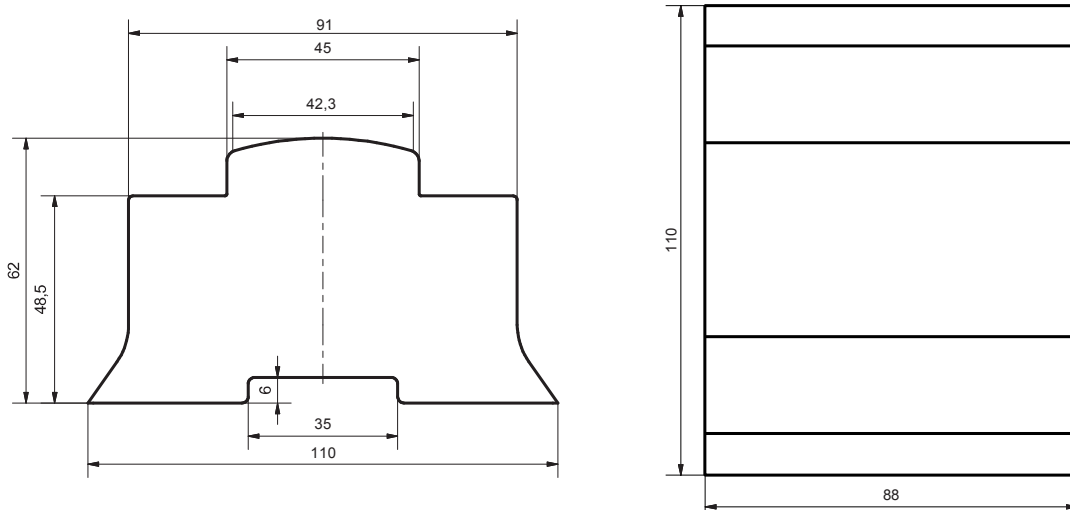

3. Communication configuration

3.1. Grounding and shielding

In most cases, IO modules will be installed in an enclosure along with other devices which generate electromagnetic radiation. Examples of these devices are relays and contactors, transformers, motor controllers etc. This electromagnetic radiation can induce electrical noise into both power and signal lines, as well as direct radiation into the module causing negative effects on the system. Appropriate grounding, shielding and other protective steps should be taken at the installation stage to prevent these effects. These protective steps include control cabinet grounding, module grounding, cable shield grounding, protective elements for electromagnetic switching devices, correct wiring as well as consideration of cable types and their cross sections.

3.2. Network Termination

Transmission line effects often present a problem on data communication networks. These problems include reflections and signal attenuation.

To eliminate the presence of reflections from the end of the cable, the cable must be terminated at both ends with a resistor across the line equal to its characteristic impedance. Both ends must be terminated since the direction of propagation is bi-directional. In the case of an RS485 twisted pair cable this termination is typically 120 Ω.

3.3. Setting Module Address in RS485 Modbus Network

The following table shows how to set switch to determine the address of the module. The module address is set with the switches in the range of 0 to 127. Addresses From 128 to 255 can be set via RS485 or USB.

Switch	Address
SW1	+1
SW2	+2
SW3	+4
SW4	+8
SW5	+16
SW6	+32
SW7	+64

Ex. if switches 1, 3 and 5 are on then module address is:

$$\text{Address} = 1 + 4 + 16 = 21$$

3.4. Types of Modbus Registers

There are 4 types of variables available in the module.

Type	Beginning address	Variable	Access	Modbus Command
1	00001	Digital Outputs	Bit Read & Write	1, 5, 15
2	10001	Digital Inputs	Bit Read	2
3	30001	Input Registers	Registered Read	3
4	40001	Output Registers	Registered Read & Write	4, 6, 16

3.5. Communication settings

The data stored in the modules memory are in 16-bit registers. Access to registers is via MODBUS RTU or MODBUS ASCII.

3.5.1. Default settings

You can restore the default configuration by the switch SW8 (see 3.5.2 - Restore the default configuration)

Boud rate	19200
Pariti	Nie
Data bits	8
Stop bits	1
Reply Delay [ms]	0
Modbus Type	RTU

3.5.2. Restore the default configuration

To restore the default configuration:

- turn off the power
- turn on the switch SW8
- turn on the power
- when power and communication LED start blinking alternately than turn off the switch SW8

Caution! After restoring the default configuration all values stored in the registers will be cleared as well.

3.5.3. Configuration registers

Modbus	Dec	Hex	Name	Values
40003	2	0x02	Baud rate	0 – 2400 1 – 4800 2 – 9600 3 – 19200 4 – 38400 5 – 57600 6 – 115200 other – value * 10
40005	4	0x04	Parity	0 – none 1 – odd 2 – even 3 – always 1 4 – always 0
40004	3	0x03	Stop Bits LSB	1 – one stop bit 2 – two stop bit
40004	3	0x03	Data Bits MSB	7 – 7 data bits 8 – 8 data bits
40006	5	0x05	Response delay	Time in ms
40007	6	0x06	Modbus Mode	0 – RTU 1 – ASCII

4. Switches

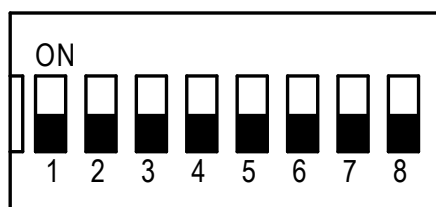

Switch	Function	Description
1	Module address +1	Setting module address from 0 to 127
2	Module address +2	
3	Module address +4	
4	Module address +8	
5	Module address +16	
6	Module address +32	
7	Module address +64	
8	Restoring default settings	Restoring default settings (see 3.5.1 - Default settings i 3.5.2 - Restore the default configuration).

5. Front panel removing

To remove the panel and gain access to the switch, you must pry open the panel using a thin tool (eg a small screwdriver) as in the picture below.



6. Indicators

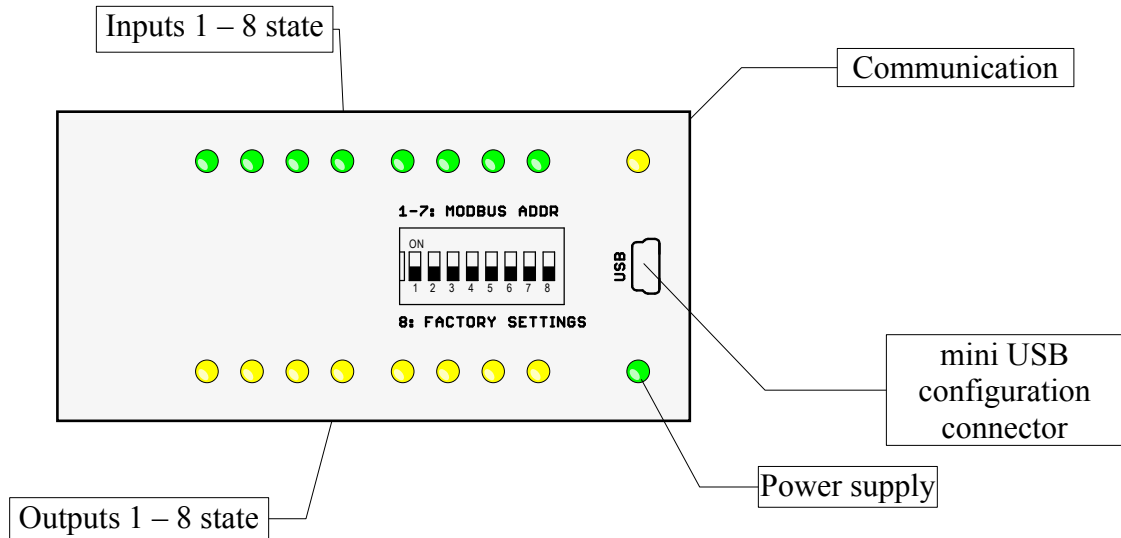

Indicators	Description
Power supply	LED indicates that the module is correctly powered.
Communication	The LED lights up when the unit received the correct packet and sends the answer.
Inputs state	LED indicates that the signal to input is connected.
Outputs state	LED indicates that the output is on.

7. Module Connection

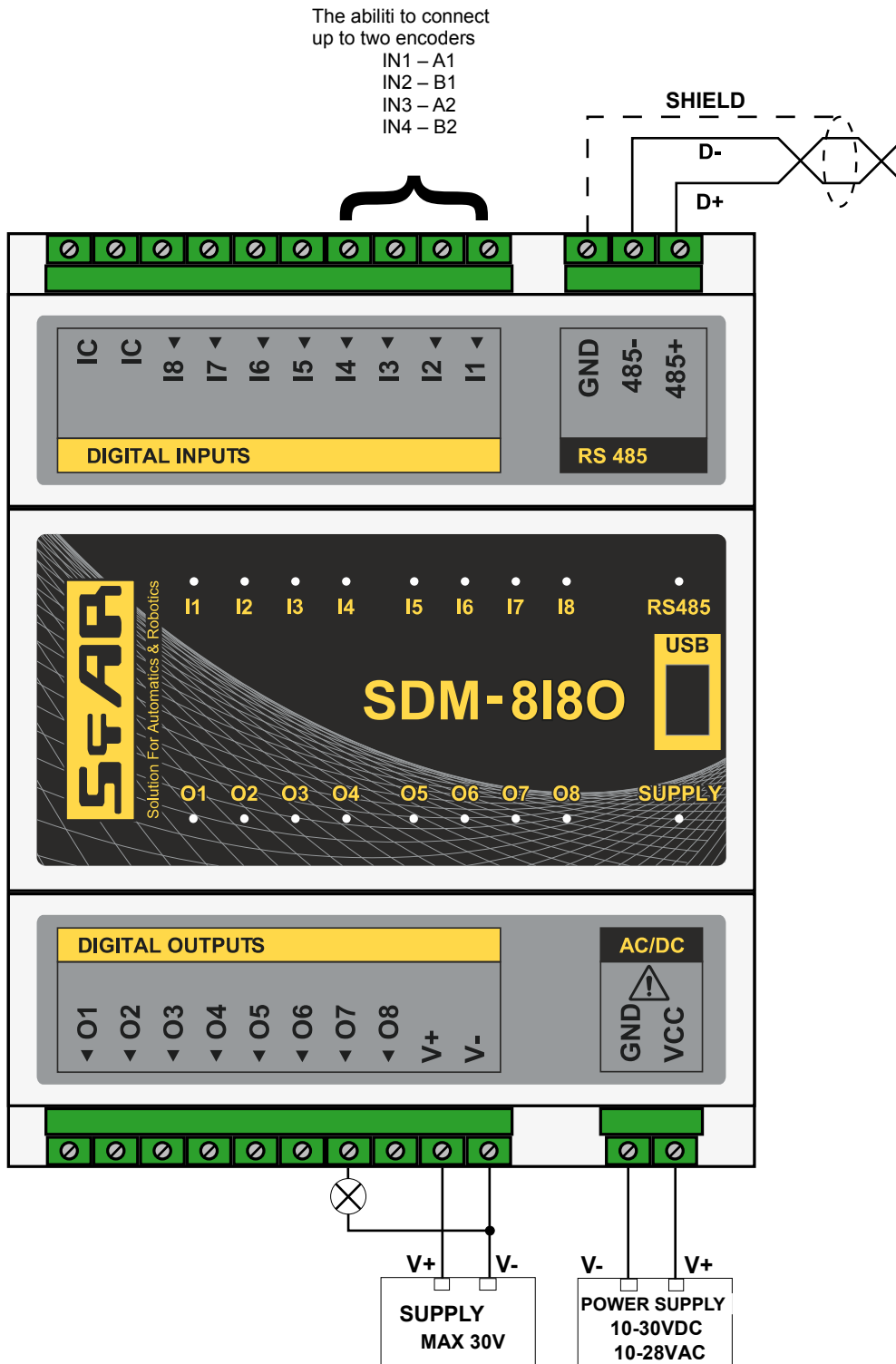

8. Modules Registers

8.1. Registered access

Modbus	Dec	Hex	Register Name	Access	Description
30001	0	0x00	Version/Type	Read	Version and Type of the device
30002	1	0x01	Switches	Read	Switches state
40003	2	0x02	Baud rate	Read & Write	RS485 baud rate
40004	3	0x03	Stop Bits & Data Bits	Read & Write	No of Stop bits & Data Bits
40005	4	0x04	Parity	Read & Write	Parity bit
40006	5	0x05	Response Delay	Read & Write	Response delay in ms
40007	6	0x06	Modbus Mode	Read & Write	Modbus Mode (ASCII or RTU)
40009	8	0x08	Watchdog	Read & Write	Watchdog
40013	12	0x0C	Default Output State	Read & Write	Default output state (after power on or watchdog reset)
40033	32	0x20	Received packets LSB	Read & Write	No of received packets
40034	33	0x21	Received packets MSB	Read & Write	
40035	34	0x22	Incorrect packets LSB	Read & Write	No of received packets with error
40036	35	0x23	Incorrect packets MSB	Read & Write	
40037	36	0x24	Sent packets LSB	Read & Write	No of sent packets
40038	37	0x25	Sent packets MSB	Read & Write	
30051	50	0x32	Inputs	Read	Inputs state
40052	51	0x33	Outputs	Read & Write	Output state
40053	52	0x34	Counter 1 LSB	Read & Write	32-bit counter 1
40054	53	0x35	Counter 1 MSB	Read & Write	
40055	54	0x36	Counter 2 LSB	Read & Write	32-bit counter 2
40056	55	0x37	Counter 2 MSB	Read & Write	
40057	56	0x38	Counter 3 LSB	Read & Write	32-bit counter 3
40058	57	0x39	Counter 3 MSB	Read & Write	
40059	58	0x3A	Counter 4 LSB	Read & Write	32-bit counter 4
40060	59	0x3B	Counter 4 MSB	Read & Write	
40061	60	0x3C	Counter 5 LSB	Read & Write	32-bit counter 5
40062	61	0x3D	Counter 5 MSB	Read & Write	
40063	62	0x3E	Counter 6 LSB	Read & Write	32-bit counter 6
40064	63	0x3F	Counter 6 MSB	Read & Write	
40065	64	0x40	Counter 7 LSB	Read & Write	32-bit counter 7
40066	65	0x41	Counter 7 MSB	Read & Write	
40067	66	0x42	Counter 8 LSB	Read & Write	32-bit counter 8
40068	67	0x43	Counter 8 MSB	Read & Write	

Modbus	Dec	Hex	Register Name	Access	Description
40085	84	0x54	CCounter 1 LSB	Read & Write	32-bit value of captured counter 1
40086	85	0x55	CCounter 1 MSB	Read & Write	
40087	86	0x56	CCounter 2 LSB	Read & Write	32-bit value of captured counter 2
40088	87	0x57	CCounter 2 MSB	Read & Write	
40089	88	0x58	CCounter 3 LSB	Read & Write	32-bit value of captured counter 3
40090	89	0x59	CCounter 3 MSB	Read & Write	
40091	90	0x5A	CCounter 4 LSB	Read & Write	32-bit value of captured counter 4
40092	91	0x5B	CCounter 4 MSB	Read & Write	
40093	92	0x5C	CCounter 5 LSB	Read & Write	32-bit value of captured counter 5
40094	93	0x5D	CCounter 5 MSB	Read & Write	
40095	94	0x5E	CCounter 6 LSB	Read & Write	32-bit value of captured counter 6
40096	95	0x5F	CCounter 6 MSB	Read & Write	
40097	96	0x60	CCounter 7 LSB	Read & Write	32-bit value of captured counter 7
40098	97	0x61	CCounter 7 MSB	Read & Write	
40099	98	0x62	CCounter 8 LSB	Read & Write	32-bit value of captured counter 8
40100	99	0x63	CCounter 8 MSB	Read & Write	
40117	116	0x74	Counter Config 1	Read & Write	<p>Counter Configuration</p> <p>+1 – time measurement (if 0 counting impulses)</p> <p>+2 – autocatch counter every 1 sec</p> <p>+4 – catch value when input low</p> <p>+8 – reset counter after catch</p> <p>+16 – reset counter if input low</p> <p>+32 – encoder (only for counter 1 and 3)</p>
40118	117	0x75	Counter Config 2	Read & Write	
40119	118	0x76	Counter Config 3	Read & Write	
40120	119	0x77	Counter Config 4	Read & Write	
40121	120	0x78	Counter Config 5	Read & Write	
40122	121	0x79	Counter Config 6	Read & Write	
40123	122	0x7A	Counter Config 7	Read & Write	
40124	123	0x7B	Counter Config 8	Read & Write	
40133	132	0x84	Catch	Read & Write	Catch counter
40134	133	0x85	Status	Read & Write	Captured counter

8.2. Bit access

Modbus Address	Dec Address	Hex Address	Register name	Access	Description
193	192	0x0C0	Default state of output 1	Read & Write	Default state of output 1
194	193	0x0C1	Default state of output 2	Read & Write	Default state of output 2
195	194	0x0C2	Default state of output 3	Read & Write	Default state of output 3
196	195	0x0C3	Default state of output 4	Read & Write	Default state of output 4
197	196	0x0C4	Default state of output 5	Read & Write	Default state of output 5
198	197	0x0C5	Default state of output 6	Read & Write	Default state of output 6
199	198	0x0C6	Default state of output 7	Read & Write	Default state of output 7
200	199	0x0C7	Default state of output 8	Read & Write	Default state of output 8
10801	800	0x320	Input 1	Read	Input 1 state
10802	801	0x321	Input 2	Read	Input 2 state
10803	802	0x322	Input 3	Read	Input 3 state
10804	803	0x323	Input 4	Read	Input 4 state
10805	804	0x324	Input 5	Read	Input 5 state
10806	805	0x325	Input 6	Read	Input 6 state
10807	806	0x326	Input 7	Read	Input 7 state
10808	807	0x327	Input 8	Read	Input 8 state
817	816	0x330	Output 1	Read & Write	Output 1 state
818	817	0x331	Output 2	Read & Write	Output 2 state
819	818	0x332	Output 3	Read & Write	Output 3 state
820	819	0x333	Output 4	Read & Write	Output 4 state
821	820	0x334	Output 5	Read & Write	Output 5 state
822	821	0x335	Output 6	Read & Write	Output 6 state
823	822	0x336	Output 7	Read & Write	Output 7 state
824	823	0x337	Output 8	Read & Write	Output 8 state
2113	2112	0x840	Capture 1	Read & Write	Capture counter 1
2114	2113	0x841	Capture 2	Read & Write	Capture counter 2
2115	2114	0x842	Capture 3	Read & Write	Capture counter 3
2116	2115	0x843	Capture 4	Read & Write	Capture counter 4
2117	2116	0x844	Capture 5	Read & Write	Capture counter 5
2118	2117	0x845	Capture 6	Read & Write	Capture counter 6
2119	2118	0x846	Capture 7	Read & Write	Capture counter 7
2120	2119	0x847	Capture 8	Read & Write	Capture counter 8

Modbus Address	Dec Address	Hex Address	Register name	Access	Description
2129	2120	0x848	Captured 1	Read & Write	Captured value of counter 1
2130	2129	0x849	Captured 2	Read & Write	Captured value of counter 2
2131	2130	0x84A	Captured 3	Read & Write	Captured value of counter 3
2132	2131	0x84B	Captured 4	Read & Write	Captured value of counter 4
2133	2132	0x84C	Captured 5	Read & Write	Captured value of counter 5
2134	2133	0x84D	Captured 6	Read & Write	Captured value of counter 6
2135	2134	0x84E	Captured 7	Read & Write	Captured value of counter 7
2136	2135	0x84F	Captured 8	Read & Write	Captured value of counter 8

9. Configuration software

Modbus Configurator is software that is designed to set the module registers responsible for communication over Modbus network as well as to read and write the current value of other registers of the module. This program can be a convenient way to test the system as well as to observe real-time changes in the registers.

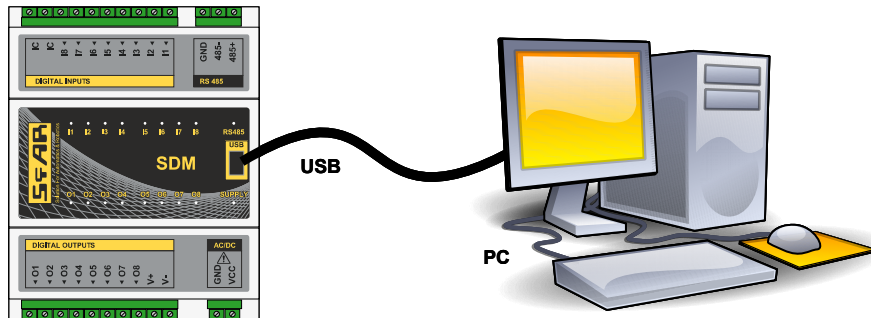

Communication with the module is done via the USB cable. The module does not require any drivers.

Configurator is a universal program, whereby it is possible to configure all available modules.

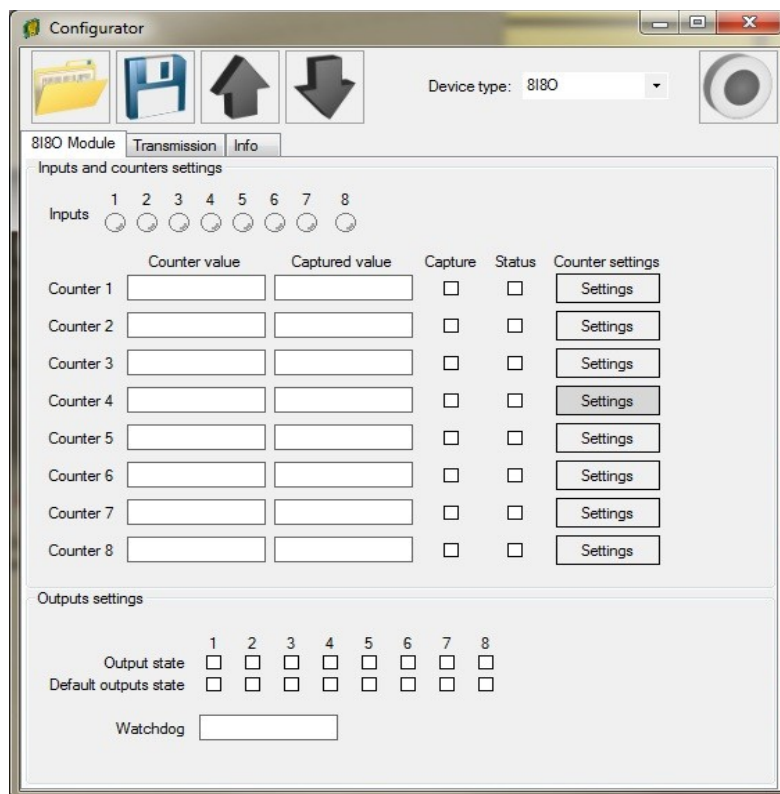

Table of content

1. Safety rules.....	3
2. Module Features.....	3
2.1. Purpose and description of the module.....	3
2.2. Technical Specifications.....	4
2.3. Dimensions of the product.....	5
3. Communication configuration.....	6
3.1. Grounding and shielding.....	6
3.2. Network Termination.....	6
3.3. Setting Module Address in RS485 Modbus Network.....	6
3.4. Types of Modbus Registers.....	7
3.5. Communication settings.....	7
3.5.1. Default settings.....	7
3.5.2. Restore the default configuration.....	7
3.5.3. Configuration registers.....	8
4. Switches.....	9
5. Front panel removing.....	10
6. Indicators.....	11
7. Module Connection.....	12
8. Modules Registers.....	13
8.1. Registered access.....	13
8.2. Bit access.....	15
9. Configuration software.....	17



Manufactured for:
Aspar s.c.
ul. Kapitańska 9
81-331 Gdynia
POLAND

ampero@ampero.eu
www.ampero.eu

Tel. +48 58 351 39 89; +48 58 732 71 73

